

Packaging Specifications

- Reel Dimensions in mm (not to scale)

SIZE	A	B	C	D	E	W	t
A,B	380±2	80min	13.0±0.5	21.0±0.8	2.0±0.5	14±1	2.0
C(8),D	380±2	80min	13.0±0.5	21.0±0.8	2.0±0.5	18±1	2.0
E,F	380±2	80min	13.0±0.5	21.0±0.8	2.0±0.5	26±1	2.0
G,H	380±2	80min	13.0±0.5	21.0±0.8	2.0±0.5	34±1	3.0
I,J	380±2	80min	13.0±0.5	21.0±0.8	2.0±0.5	46±1	3.0
K,L	380±2	80min	13.0±0.5	21.0±0.8	2.0±0.5	46±1	3.0

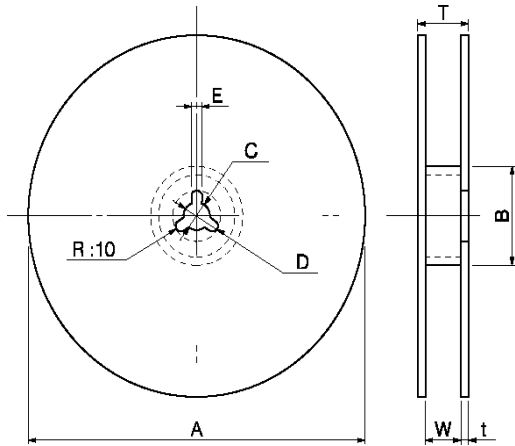

→ Pull out direction

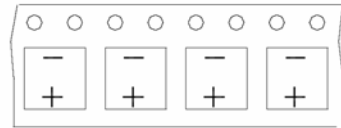

- Taping Dimensions in mm (not to scale)

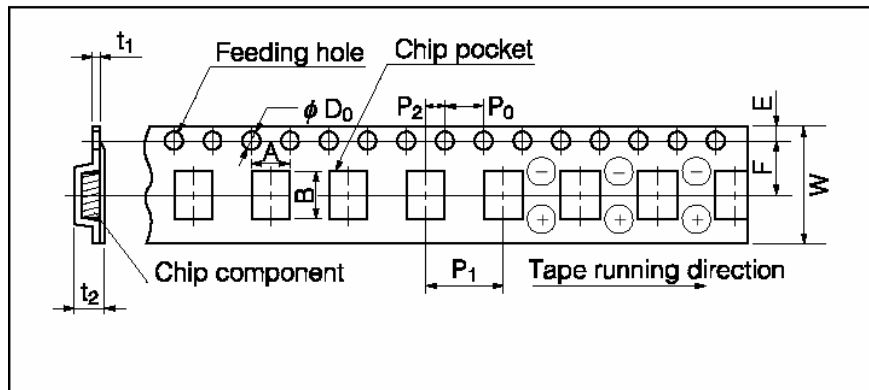

SIZE	W	A	B	P ₀ ±0.1	P ₁	P ₂ ±0.1	F	ψD ₀ ^{±0.1}	t ₁	E	t ₂	Q'ty per Reel
A (4X5.7)	12.0	5.0	5.0	4.0	8.0	2.0	5.5	1.5	0.4	1.75	5.8	2000
B (5X5.7)	12.0	6.0	6.0	4.0	12.0	2.0	5.5	1.5	0.4	1.75	5.8	1000
C (6.3X5.7)	16.0	7.0	7.0	4.0	12.0	2.0	5.5	1.5	0.4	1.75	5.8	1000
C8 (6.3X7.7)	16.0	7.0	7.0	4.0	12.0	2.0	5.5	1.5	0.4	1.75	8.4	1000
D (8X6.5)	16.0	8.7	8.7	4.0	12.0	2.0	7.5	1.5	0.4	1.75	6.8	1000
E (8X10.5)	24.0	8.7	8.7	4.0	16.0	2.0	11.5	1.5	0.4	1.75	11.0	500
F (10X10.5)	24.0	10.7	10.7	4.0	16.0	2.0	11.5	1.5	0.4	1.75	11.0	500
G (12.5X13.5)	32.0	13.4	13.4	4.0	24.0	2.0	14.2	1.5	0.5	1.75	14.0	200
H (12.5X16)	32.0	13.4	13.4	4.0	24.0	2.0	14.2	1.5	0.5	1.75	17.5	200
I (16X16.5)	44.0	17.5	17.5	4.0	28.0	2.0	20.2	1.5	0.5	1.75	17.5	125
J (16X21.5)	44.0	17.5	17.5	4.0	28.0	2.0	20.2	1.5	0.5	1.75	22.5	100
K (18X16.5)	44.0	19.5	19.5	4.0	32.0	2.0	20.2	1.5	0.5	1.75	17.5	125
L (18X21.5)	44.0	19.5	19.5	4.0	32.0	2.0	20.2	1.5	0.5	1.75	22.5	100