

Data Sheet

Customer: _____

Product: SMD Aluminum Electrolytic Capacitors – EMV Series

Size : 4x5.7mm ~ 18x16.5mm

Issued Date: 06-Nov.-2024

Edition: Ver.4

Record of change

Date	Ver.	Description	Page
15-May-2016	1		
27-Feb.-2024	2	Delete EMV101M0JRC	3
24-Jun.-2024	3	Revised Load Life $D \leq 6.3\text{mm}$: 3000hrs, $D \geq 8\text{mm}$: 5000hrs	2
06-Nov.-2024	4	Revised Dimension graphics	2

HITANO ENTERPRISE CORP.

7F-7, No. 3, Wu Chuan 1st Road, New Taipei Industrial
Park, New Taipei City, TAIWAN, R.O.C.

Tel: +886 2 2299 1331 (Rep.)

Fax: +886 2 2298 2466, 2298 2969

Prepared by	Checked by	Approved by	Accepted by (customer)
06-Nov.-2024	06-Nov.-2024	06-Nov.-2024	
Randy Yu	Michelle Lin	Arthur Su	

- SMD TYPE Reflow Soldering is available
- 105°C, 3000~5000 hours assured
- Available For High Density Mounting

Characteristics

Voltage Range	6.3 ~ 100V								
Temperature Range	-40°C ~ +105°C								
Capacitance Tolerance	±20% (at 120Hz, 20°C)								
Leakage Current	I≤0.01CV or 3uA, whichever is greater 2 minutes after Rated Voltage applied								
Dissipation Factor (tanδ)Max (at 120Hz, 20°C)	Rated Voltage (V)	6.3	10	16	25	35	50	63	100
	D.F.(tanδ)	0.32	0.28	0.22	0.16	0.13	0.12	0.089	0.07
Stability at Low Temperature (at 120Hz)	Rated Voltage (V)	6.3	10	16	25	35	50	63	100
	Z-25°C/Z 20°C	4	3	2	2	2	2	2	2
	Z-40°C/Z 20°C	10	7	5	3	3	3	3	3
Load Life After the rated voltage has been applied for 3000~5000 hours at 105°C	3000hrs for D ≤ 6.3mm, 5000hrs for D ≥ 8mm	Capacitance change			Within ±30% of initial value				
		D.F. tanδ			Less than ±300% of specified value				
		Leakage current			Less than Initial specified value				
Shelf Life	After storage for 1000 hours at 105°C, with no voltage applied and being stabilized at +20°C, Capacitor shall meet the limit specified in load life.(Refer to JIS C5101-4 4.1)								

Diagram of dimensions

SIZE	Dφ	L	A	B	C	W	P±0.2
A	4	5.7±0.3	4.3	4.3	5.1	0.5~0.8	1.0
B	5	5.7±0.3	5.3	5.3	5.9	0.5~0.8	1.5
C	6.3	5.7±0.3	6.6	6.6	7.2	0.5~0.8	2.0
C8	6.3	7.7±0.3	6.6	6.6	7.2	0.5~0.8	2.0
D	8	6.5±0.3	8.4	8.4	9.0	0.5~0.8	2.3
E	8	10.5±0.3	8.4	8.4	9.0	0.7~1.1	3.1
F	10	10.5±0.3	10.4	10.4	11.0	0.7~1.3	4.5
G	12.5	14±0.5	13.5	13.5	15.0	1.1~1.4	4.5
H	12.5	16±0.5	13.0	13.0	15.0	1.1~1.4	4.5
I	16	16.5±0.5	17.0	17.0	18.0	1.1~1.4	6.4
J	16	21.5±0.5	17.0	17.0	18.0	1.1~1.4	6.4
K	18	16.5±0.5	19.0	19.0	20.0	1.1~1.4	6.4

Size A~H refer to Fig. 1

Size I~K refer to Fig. 2

Fig. 1

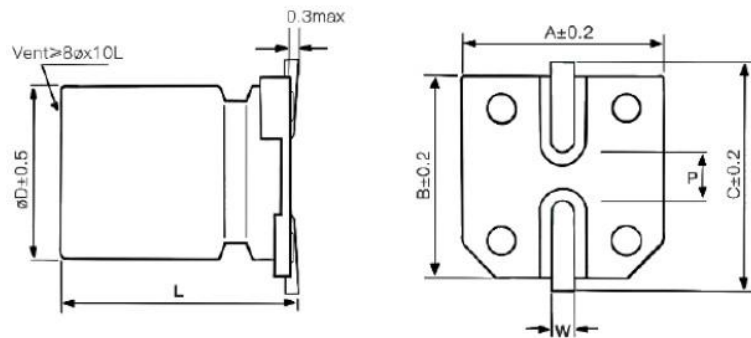
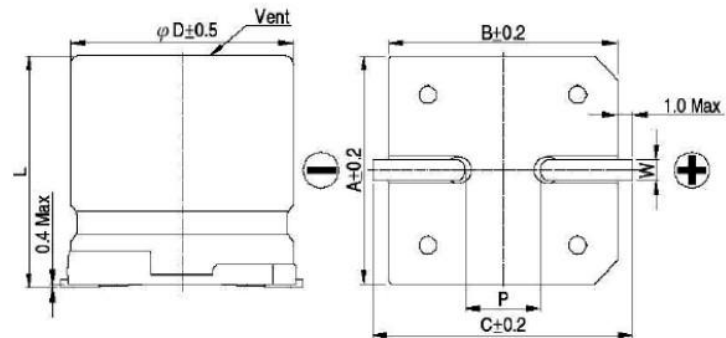

Fig. 2



Multiplier for Ripple Current vs Frequency

CAP(uF)\Freq(Hz)	60(50)	120	500	1K	≥10K
0.1 ≤ CAP ≤ 100	0.8	1.0	1.20	1.30	1.50
100 < CAP	0.8	1.0	1.10	1.15	1.20

Case size & Maximum Ripple Current (mA rms 105°C 120Hz)

Cap. uF	6.3		10		16		25	
	Size	RC	Size	RC	Size	RC	Size	RC
1								
2.2								
3.3								
4.7							A	13
10					A	17	A	23
22	A	22	B	28	B	30	C	40
33	B	32	B	34	C	44	C	48
47	B	36	C	48	C	50	C8	63
100			C8	79	C8	81	E	116
220	C8	110	E	140	F	216	F	240
330	E	160	F	240	F	300	F	375
470	F	260	F	280	F	320		
1000	F	340						

Cap. uF	35		50		63		100	
	Size	RC	Size	RC	Size	RC	Size	RC
1			A	6.2				
2.2			A	11				
3.3			A	14				
4.7	A	15	B	19				
10	B	25	C	30				
22	C	42	C8	52				
33	C8	57	E	80				
47	E	92	E	95				
100	F	150	F	160			H	240
220	F	280	G	280	G	320	I	340
330	G	320	H	360	H	450	I	410
470	H	410	I	510	I	540	K	540
1000	I	690	K	780				

Part Numbering System

EMV □ □ □ **M** □ □ **R** □
 Series Capacitance Tolerance Rated Voltage Package Case Size