



HITANO ENTERPRISE CORP.

7F-7, No. 3, Wu Chuan 1st Road, New Taipei
Industrial Park, New Taipei City, TAIWAN, R.O.C.
Tel: +886 2 2299 1331 Fax: +886 2 2298 2466

Data Sheet

Customer: _____

Product : DC-Link Capacitors for PCB Application (Automotive Grade)

Size: _____

Issued Date: 2023-11-16

Edition : CC81823111601

Record of change

Date	Ver.	Description	Page
2024-07-09	1.0		

VENDOR :

HITANO ENTERPRISE CORP.

7F-7,NO.3,WUCHUAN1ST ROAD,
NEW TAIPEI INDUSTRIAL PARK,
NEW TAIPEI CITY, TAIWAN, R.O.C.
TEL:+886222991331(REP.)
FAX:+886222982466



MAKER :

CHIEFCON ELECTRONICS CO.,LTD.

NO.23,HER-CHENG RD,BA-DE
DISTRIC CITY TAO YUAN CITY, 334 TAIWAN.R.O.C
Tel: +886-3-3623092&3641144
Fax: +886-3-3623273



DC-Link Capacitors for PCB Application (Automotive Grade)

FEATURES

- Very Low Dissipation Factor.
- Very Low ESR And ESL.
- Excellent Self-Healing Performance.
- High Stability and Reliability.

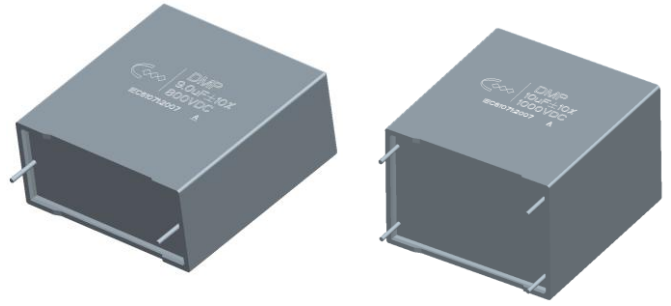

STRUCTURE

- Metallized Polypropylene Film Non-Inductive Construction.
- Cu Lead Wire or Cu Terminals Connected.
- Flame Retardant Plastic Case and Epoxy Resin Encapsulated.
- Dry Type Structure.

TYPE APPLICATION

- Frequency Converters, Industrial and High-End Power Supplies, Solar Invertor.

SPECIFICATIONS

Type	HEK									
Reference standard	IEC 61071, GB T17702.1:2013									
Climatic category	40/105/56									
Operating Temperature	-40°C ~105°C (+85°C to +105°C: decreasing factor 1.25% per °C for Un, 85°C)									
Uop (VDC) at 70°C	500	650	700	800	900	1000	1100	1200	1300	
Un (VDC) at 85°C	450	550	600	700	800	900	1000	1100	1200	
Uop (VDC) at 105°C	300	400	440	490	560	630	700	770	840	
Capacitance range(μF)	5~200	5~180	2~140	2~140	2~110	1~85	1~70	1~55	1~45	
Dissipation Factor	≤0.002 (0.2%) at 1KHz; C ≤20μF at 25°C ≤0.003 (0.3%) at 1KHz; C >20μF at 25°C ≤0.004 (0.4%) at 1KHz; C >80μF at 25°C									
Capacitance tolerance	±5%(J), ±10%(K), ±20%(M)									
Insulation Resistance	RC between leads, IR *C≥30,000 s at 100vdc 1minute at +25°C ±5°C									
ESR (at 10KHZ)	Reference Page 2-7									
Voltage Between Terminals UTT	1.5*Un VDC for 10 sec (between terminations) at +25°C ±5°C									
Voltage Between Terminals and Case UTC	3000VAC, 50/60Hz 60s (at +25 ±5°C)									
Self-inductance	<1nH per mm of lead spacing									
Max. Altitude	2,000 m									
Life Expectancy	100,000 hours (Un, Θhotspot=85°C)									

PART NUMBER SYSTEM

1	2	3	4	5	6	7	8	9	10
Type	Class	Capacitance Code (pF)	Tolerance	Rated Voltage(VDC)	Lead Configuration	Lead Space	Vice Lead(P1)	Lead Length	Accessories Yards
HE= DMP	K= BOX AECQ200	First two digits = significant figures. Third digit = Number of zeros.	J=5% K=10% M=20%	2W=450 4C=550 2T=600 2S=700 2K=800 2P=900 3A=1000 3J=1100 3M=1200	B=Lead (2 PIN) R=Lead (4 PIN)	K=27.5mm Q=37.5mm 1=52.5mm	J=10.2 N=20.3 X=NA	5=5.0mm	The last code show "**", which is temporary P/N.

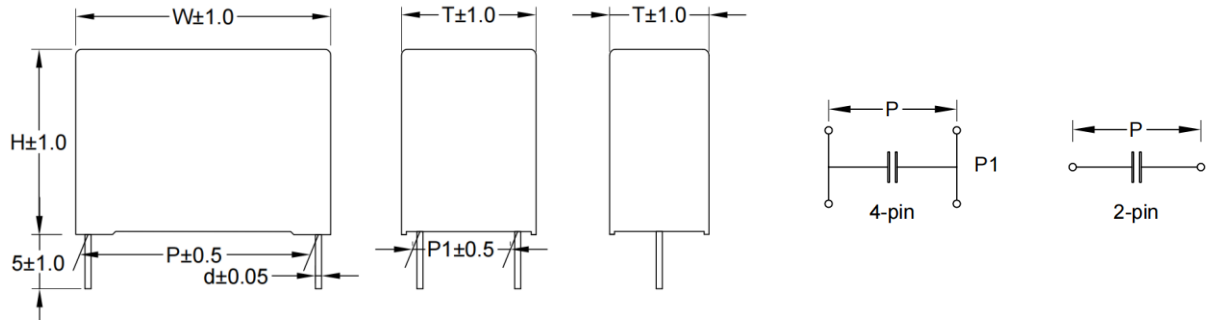

$U_{OP} = 500VDC$ at $70^\circ C$ $U_n = 450VDC$ at $85^\circ C$ $U_{OP} = 300VDC$ at $105^\circ C$

CAP. (μF)	Dimensions in mm						dv/dt	Peak Current	Surge Current	ESR 10KHz	ESL	Thermal Res	Irms* 10KHz
	W	H	T	P	P1	ϕd	V/us	A	A	m Ω	nH	$^\circ C/W$	A $85^\circ C$
5	32.0	20.0	11.0	27.5	NA	0.8	65	325	975	20.0	25	30	5.0
10	32.0	25.5	16.0	27.5	NA	0.8	65	650	1950	11.0	25	27.8	7.0
15	31.0	33.0	18.0	27.5	NA	0.8	65	975	2925	7.0	25	17.7	11.0
22	32.0	37.0	22.0	27.5	NA	0.8	65	1430	4290	5.0	28	24.8	11.0
25	32.0	37.0	22.0	27.5	NA	0.8	65	1625	4875	4.8	28	24.8	12.0
30	42.0	40.0	20.0	37.5	10.2	1.0	35	1050	3150	7.5	30	12.8	12.5
35	42.5	37.0	22.0	37.5	10.2	1.0	35	1225	3675	7.0	30	11.8	13.5
40	42.5	37.0	28.0	37.5	10.2	1.0	35	1400	4200	6.2	30	11.5	14.5
50	41.5	41.0	27.5	37.5	10.2	1.0	35	1750	5250	5.0	30	11.7	16.0
50	41.5	45.0	30.0	37.5	20.3	1.0	35	1750	5250	5.0	30	11.7	16.0
60	41.5	45.0	30.0	37.5	20.3	1.0	35	2100	6300	4.5	30	12.2	16.5
75	57.5	45.0	30.0	52.5	20.3	1.2	20	1500	4500	5.5	35	10	16.5
80	57.5	45.0	30.0	52.5	20.3	1.2	20	1600	4800	5.0	35	10.4	17.0
100	57.5	50.0	35.0	52.5	20.3	1.2	20	2000	6000	4.5	35	10.3	18.0
110	57.5	50.0	35.0	52.5	20.3	1.2	20	2200	6600	4.0	35	10.4	19.0
120	57.5	50.0	35.0	52.5	20.3	1.2	20	2400	7200	3.8	35	10.4	21.5
150	57.5	65.0	35.0	52.5	20.3	1.2	20	3000	9000	3.6	35	10.4	24.5
160	58.0	55.0	45.0	52.5	20.3	1.2	20	3200	9600	3.0	35	10.4	28.5
200	58.0	67.0	45.0	52.5	20.3	1.2	20	4000	12000	2.6	35	10.4	33.0

$U_{OP} = 650VDC$ at $70^\circ C$ $U_n = 550VDC$ at $85^\circ C$ $U_{OP} = 400VDC$ at $105^\circ C$

5	31.0	22.0	13.0	27.5	NA	0.8	65	325	975	19.5	25	25.4	5.5
10	31.0	33.0	18.0	27.5	NA	0.8	65	650	1950	10.5	25	25.4	7.5
15	32.0	37.0	22.0	27.5	NA	0.8	65	975	2925	6.8	28	16.7	11.5
22	32.0	37.0	22.0	27.5	NA	0.8	65	1430	4290	4.9	28	23.1	11.5
30	42.5	44.0	24.0	37.5	10.2	1.0	35	1050	3150	7.2	30	12.3	13.0
35	41.5	45.0	30.0	37.5	20.3	1.0	35	1225	3675	6.8	30	11.6	13.8
40	41.5	45.0	30.0	37.5	20.3	1.0	35	1400	4200	6.0	30	11.4	14.8
75	57.5	45.0	30.0	52.5	20.3	1.2	20	1500	4500	5.2	35	10.2	16.8
100	57.5	50.0	35.0	52.5	20.3	1.2	20	2000	6000	4.3	35	10.2	18.5
110	57.5	50.0	35.0	52.5	20.3	1.2	20	2200	6600	4.0	35	9.4	20.0
140	58.0	55.0	45.0	52.5	20.3	1.2	20	2800	8400	3.5	35	6.3	26.0
170	58.0	67.0	45.0	52.5	20.3	1.2	20	3400	10200	2.8	35	5.2	32.0
180	58.0	67.0	45.0	52.5	20.3	1.2	20	3600	10800	2.6	35	5.2	33.0

U _{OP} = 700VDC at 70°C U _n = 600VDC at 85°C U _{OP} = 440VDC at 105°C													
CAP. (uF)	Dimensions in mm						dv/dt	Peak Current	Surge Current	ESR 10KHz	ESL	Thermal Res	Irms* 10KHz
	W	H	T	P	P1	φd	V/us	A	A	mΩ	nH	°C/W	A 85°C
2	32.0	18.0	9.0	27.5	NA	0.8	65	130	390	40.0	25	44.6	2.9
3	32.0	20.0	11.0	27.5	NA	0.8	65	195	585	28.0	25	33.5	4.0
4	32.0	20.0	11.0	27.5	NA	0.8	65	260	780	23.0	25	21.6	5.5
5	31.0	22.0	13.0	27.5	NA	0.8	65	325	975	14.5	25	21.1	7.0
6	32.0	25.5	16.0	27.5	NA	0.8	65	390	1170	13.0	25	21.7	7.3
7	32.0	25.5	16.0	27.5	NA	0.8	65	455	1365	12.0	25	17.3	8.5
8	32.0	28.0	14.0	27.5	NA	0.8	65	520	1560	11.0	25	15.1	9.5
9	32.0	30.0	15.0	27.5	NA	0.8	65	585	1755	10.5	25	13	10.5
10	32.0	30.0	15.0	27.5	NA	0.8	65	650	1950	10.0	25	12.4	11.0
12	31.0	33.0	18.0	27.5	NA	0.8	65	780	2340	9.5	25	11	12.0
15	32.0	37.0	22.0	27.5	NA	0.8	65	975	2925	9.5	28	11	12.0
15	32.0	37.0	22.0	27.5	10.2	0.8	65	975	2925	7.0	28	10.2	14.5
18	32.0	37.0	22.0	27.5	NA	0.8	65	1170	3510	9.0	28	10.7	12.5
18	32.0	37.0	22.0	27.5	10.2	0.8	65	1170	3510	6.0	28	9.2	16.5
10	41.5	30.0	17.0	37.5	NA	1.0	35	350	1050	18.0	28	17	7.0
12	41.5	30.0	17.0	37.5	NA	1.0	35	420	1260	12.0	28	19.5	8.0
15	42.0	33.5	18.5	37.5	NA	1.0	35	525	1575	11.0	28	15.1	9.5
20	42.0	40.0	20.0	37.5	10.2	1.0	35	700	2100	9.0	30	10.7	12.5
22	42.0	40.0	20.0	37.5	10.2	1.0	35	770	2310	8.0	30	10.3	13.5
25	42.0	40.0	20.0	37.5	10.2	1.0	35	875	2625	7.0	30	8.9	15.5
30	42.5	44.0	24.0	37.5	10.2	1.0	35	1050	3150	6.5	30	8.5	16.5
35	41.5	45.0	30.0	37.5	20.3	1.0	35	1225	3675	6.0	30	7.3	18.5
40	41.5	45.0	30.0	37.5	20.3	1.0	35	1400	4200	5.0	30	7.1	20.5
55	57.5	45.0	30.0	52.5	20.3	1.2	20	1100	3300	6.2	35	8.4	17.0
60	57.5	45.0	30.0	52.5	20.3	1.2	20	1200	3600	6.0	35	7.3	18.5
65	57.5	50.0	35.0	52.5	20.3	1.2	20	1300	3900	5.5	35	6.8	20.0
70	57.5	50.0	35.0	52.5	20.3	1.2	20	1400	4200	5.0	35	6.5	21.5
75	57.5	50.0	35.0	52.5	20.3	1.2	20	1500	4500	4.5	35	6.0	23.5
80	57.5	50.0	35.0	52.5	20.3	1.2	20	1600	4800	4.2	35	5.9	24.5
90	58.0	55.0	45.0	52.5	20.3	1.2	20	1800	5400	4.0	35	5.5	26.0
100	58.0	55.0	45.0	52.5	20.3	1.2	20	2000	6000	3.4	35	5.2	29.0
110	58.0	55.0	45.0	52.5	20.3	1.2	20	2200	6600	3.0	35	5.6	30.0
120	58.0	67.0	45.0	52.5	20.3	1.2	20	2400	7200	2.8	35	5.2	32.0
130	58.0	67.0	45.0	52.5	20.3	1.2	20	2600	7800	2.6	35	5.3	33.0
U _{OP} = 800VDC at 70°C U _n = 700VDC at 85°C U _{OP} = 490VDC at 105°C													
2	32.0	18.0	9.0	27.5	NA	0.8	65	130	390	40.0	25	44.6	2.9
3	32.0	20.0	11.0	27.5	NA	0.8	65	195	585	28.0	25	33.5	4.0
4	32.0	20.0	11.0	27.5	NA	0.8	65	260	780	23.0	25	21.6	5.5
5	31.0	22.0	13.0	27.5	NA	0.8	65	325	975	14.5	25	21.1	7.0
6	32.0	25.5	16.0	27.5	NA	0.8	65	390	1170	13.0	25	21.7	7.3
7	32.0	25.5	16.0	27.5	NA	0.8	65	455	1365	12.0	25	17.3	8.5
8	32.0	28.0	14.0	27.5	NA	0.8	65	520	1560	11.0	25	15.1	9.5
9	32.0	30.0	15.0	27.5	NA	0.8	65	585	1755	10.5	25	13.0	10.5
10	32.0	30.0	15.0	27.5	NA	0.8	65	650	1950	10.0	25	12.4	11.0

CAP. (μ F)	Dimensions in mm						dv/dt	Peak Current	Surge Current	ESR 10KHz	ESL	Thermal Res	Irms* 10KHz
	W	H	T	P	P1	ϕ d	V/us	A	A	m Ω	nH	$^{\circ}$ C/W	A 85 $^{\circ}$ C
12	31.0	33.0	18.0	27.5	NA	0.8	65	780	2340	9.5	25	11.0	12.0
15	32.0	37.0	22.0	27.5	NA	0.8	65	975	2925	9.5	28	11.0	12.0
15	32.0	37.0	22.0	27.5	10.2	0.8	65	975	2925	7.0	28	10.2	14.5
18	32.0	37.0	22.0	27.5	NA	0.8	65	1170	3510	9.0	28	10.7	12.5
18	32.0	37.0	22.0	27.5	10.2	0.8	65	1170	3510	6.0	28	9.2	16.5
10	41.5	30.0	17.0	37.5	NA	1.0	35	350	1050	18.0	28	17.0	7.0
12	41.5	30.0	17.0	37.5	NA	1.0	35	420	1260	12.0	28	19.5	8.0
15	42.0	33.5	18.5	37.5	NA	1.0	35	525	1575	11.0	28	15.1	9.5
20	42.0	40.0	20.0	37.5	10.2	1.0	35	700	2100	9.0	30	10.7	12.5
22	42.0	40.0	20.0	37.5	10.2	1.0	35	770	2310	8.0	30	10.3	13.5
25	42.0	40.0	20.0	37.5	10.2	1.0	35	875	2625	7.0	30	8.9	15.5
30	42.5	44.0	24.0	37.5	10.2	1.0	35	1050	3150	6.5	30	8.5	16.5
35	41.5	45.0	30.0	37.5	20.3	1.0	35	1225	3675	6.0	30	7.3	18.5
40	41.5	45.0	30.0	37.5	20.3	1.0	35	1400	4200	5.0	30	7.1	20.5
55	57.5	45.0	30.0	52.5	20.3	1.2	20	1100	3300	6.2	35	8.4	17.0
60	57.5	45.0	30.0	52.5	20.3	1.2	20	1200	3600	6.0	35	7.3	18.5
65	57.5	50.0	35.0	52.5	20.3	1.2	20	1300	3900	5.5	35	6.8	20.0
70	57.5	50.0	35.0	52.5	20.3	1.2	20	1400	4200	5.0	35	6.5	21.5
75	57.5	50.0	35.0	52.5	20.3	1.2	20	1500	4500	4.5	35	6.0	23.5
80	57.5	50.0	35.0	52.5	20.3	1.2	20	1600	4800	4.2	35	5.9	24.5
90	58.0	55.0	45.0	52.5	20.3	1.2	20	1800	5400	4.0	35	5.5	26.0
100	58.0	55.0	45.0	52.5	20.3	1.2	20	2000	6000	3.4	35	5.2	29.0
110	58.0	55.0	45.0	52.5	20.3	1.2	20	2200	6600	3.0	35	5.6	30.0
120	58.0	67.0	45.0	52.5	20.3	1.2	20	2400	7200	2.8	35	5.2	32.0
130	58.0	67.0	45.0	52.5	20.3	1.2	20	2600	7800	2.6	35	5.3	33.0
140	58.0	67.0	45.0	52.5	20.3	1.2	20	2800	8400	2.5	35	5.2	34.0
$U_{OP} = 900VDC$ at 70 $^{\circ}$ C $U_n = 800VDC$ at 85 $^{\circ}$ C $U_{OP} = 560VDC$ at 105 $^{\circ}$ C													
2	32.0	18.0	9.0	27.5	NA	0.8	65	130	390	40.0	25	44.6	2.9
3	32.0	20.0	11.0	27.5	NA	0.8	65	195	585	26.0	25	28.5	4.5
4	31.0	25.0	14.0	27.5	NA	0.8	65	260	780	22.0	25	20.3	5.8
5	32.0	25.5	16.0	27.5	NA	0.8	65	325	975	14.0	25	19.0	7.5
6	32.0	30.0	15.0	27.5	NA	0.8	65	390	1170	12.0	25	17.3	8.5
7	32.0	30.0	15.0	27.5	NA	0.8	65	455	1365	11.0	25	15.1	9.5
8	31.0	33.0	18.0	27.5	NA	0.8	65	520	1560	10.5	25	13.0	10.5
9	31.0	33.0	18.0	27.5	NA	0.8	65	585	1755	10.2	25	11.1	11.5
10	32.0	37.0	22.0	27.5	NA	0.8	65	650	1950	9.5	25	11.0	12.0
10	32.0	37.0	22.0	27.5	10.2	0.8	65	650	1950	8.5	25	9.0	14.0
12	32.0	37.0	22.0	27.5	NA	0.8	65	780	2340	9.5	25	11.0	12.0
12	32.0	37.0	22.0	27.5	10.2	0.8	65	780	2340	8.0	25	8.3	15.0
14	32.0	37.0	22.0	27.5	NA	0.8	65	910	2730	9.5	25	11.0	12.0
14	32.0	37.0	22.0	27.5	10.2	0.8	65	910	2730	7.5	25	7.8	16.0
8	41.5	30.0	17.0	37.5	NA	1.0	35	280	840	22.5	28	22.0	5.5
9	41.5	30.0	17.0	37.5	NA	1.0	35	315	945	21.5	28	19.4	6.0
10	42.0	33.5	18.5	37.5	NA	1.0	35	350	1050	18.0	28	17.0	7.0
12	42.0	33.5	18.5	37.5	NA	1.0	35	420	1260	12.0	28	19.5	8.0

CAP. (μ F)	Dimensions in mm						dv/dt	Peak Current	Surge Current	ESR 10KHz	ESL	Thermal Res	I _{rms} * 10KHz
	W	H	T	P	P1	ϕ d	V/us	A	A	m Ω	nH	$^{\circ}$ C/W	A 85 $^{\circ}$ C
14	42.0	33.5	18.5	37.5	NA	1.0	35	490	1470	11.0	28	15.1	9.5
15	42.0	40.0	20.0	37.5	10.2	1.0	35	525	1575	9.0	30	10.7	12.5
20	42.5	44.0	24.0	37.5	10.2	1.0	35	700	2100	8.0	30	10.3	13.5
25	42.5	44.0	24.0	37.5	10.2	1.0	35	875	2625	6.5	30	8.5	16.5
30	41.5	45.0	30.0	37.5	20.3	1.0	35	1050	3150	5.8	30	6.5	20.0
40	57.5	45.0	30.0	52.5	20.3	1.2	20	800	2400	8.5	35	9.0	14.0
45	57.5	45.0	30.0	52.5	20.3	1.2	20	900	2700	7.0	35	8.9	15.5
50	57.5	50.0	35.0	52.5	20.3	1.2	20	1000	3000	5.8	35	8.9	17.0
55	57.5	50.0	35.0	52.5	20.3	1.2	20	1100	3300	5.5	35	7.6	19.0
60	57.5	50.0	35.0	52.5	20.3	1.2	20	1200	3600	4.8	35	7.1	21.0
65	58.0	55.0	45.0	52.5	20.3	1.2	20	1300	3900	4.6	35	6.4	22.5
70	58.0	55.0	45.0	52.5	20.3	1.2	20	1400	4200	4.5	35	5.8	24.0
75	58.0	55.0	45.0	52.5	20.3	1.2	20	1500	4500	4.3	35	5.4	25.5
80	58.0	55.0	45.0	52.5	20.3	1.2	20	1600	4800	4.2	35	5.3	26.0
90	58.0	55.0	45.0	52.5	20.3	1.2	20	1800	5400	4.0	35	5.0	27.5
100	58.0	67.0	45.0	52.5	20.3	1.2	20	2000	6000	3.2	35	4.7	31.5
110	58.0	67.0	45.0	52.5	20.3	1.2	20	2200	6600	3.0	35	4.3	34.0
$U_{OP} = 1000VDC$ at 70 $^{\circ}$ C $U_n = 900VDC$ at 85 $^{\circ}$ C $U_{OP} = 630VDC$ at 105 $^{\circ}$ C													
1	32.0	18.0	9.0	27.5	NA	0.8	70	70	210	65.0	25	57.7	2.0
2	32.0	20.0	11.0	27.5	NA	0.8	70	140	420	38.0	25	38.5	3.2
3	31.0	22.0	13.0	27.5	NA	0.8	70	210	630	30.0	25	21.7	4.8
4	32.0	25.5	16.0	27.5	NA	0.8	70	280	840	20.5	25	20.3	6.0
5	32.0	30.0	15.0	27.5	NA	0.8	70	350	1050	12.0	25	22.2	7.5
6	31.0	33.0	18.0	27.5	NA	0.8	70	420	1260	11.5	25	21.4	7.8
7	31.0	33.0	18.0	27.5	NA	0.8	70	490	1470	10.2	25	13.3	10.5
8	32.0	37.0	22.0	27.5	NA	0.8	70	560	1680	9.5	25	11.9	11.5
8	32.0	37.0	22.0	27.5	10.2	0.8	70	560	1680	9.0	25	10.7	12.5
9	32.0	37.0	22.0	27.5	NA	0.8	70	630	1890	9.7	25	11.1	11.8
9	32.0	37.0	22.0	27.5	10.2	0.8	70	630	1890	7.8	25	9.8	14.0
10	32.0	37.0	22.0	27.5	NA	0.8	70	700	2100	9.5	25	11.0	12.0
10	32.0	37.0	22.0	27.5	10.2	0.8	70	700	2100	7.2	25	8.7	15.5
5	41.5	30.0	17.0	37.5	NA	1.0	35	175	525	28.0	28	37.1	3.8
6	41.5	30.0	17.0	37.5	NA	1.0	35	210	630	25.0	28	29.6	4.5
7	41.5	30.0	17.0	37.5	NA	1.0	35	245	735	22.0	28	27.3	5.0
8	42.0	33.5	18.5	37.5	NA	1.0	35	280	840	19.5	28	21.4	6.0
10	42.0	40.0	20.0	37.5	10.2	1.0	35	350	1050	13.0	30	20.5	7.5
12	42.5	37.0	22.0	37.5	10.2	1.0	35	420	1260	11.5	30	16.1	9.0
15	42.5	44.0	24.0	37.5	10.2	1.0	35	525	1575	10.5	30	13.0	10.5
18	42.5	44.0	24.0	37.5	10.2	1.0	35	630	1890	8.8	30	10.1	13.0
20	42.5	44.0	24.0	37.5	10.2	1.0	35	700	2100	7.5	30	9.5	14.5
25	41.5	45.0	30.0	37.5	20.3	1.0	35	875	2625	6.2	30	7.9	17.5
30	57.5	45.0	30.0	52.5	20.3	1.2	20	600	1800	10.0	35	12.4	11.0
35	57.5	45.0	30.0	52.5	20.3	1.2	20	700	2100	9.0	35	10.7	12.5
40	57.5	50.0	35.0	52.5	20.3	1.2	20	800	2400	7.5	35	9.5	14.5
45	57.5	50.0	35.0	52.5	20.3	1.2	20	900	2700	6.8	35	8.6	16.0

CAP. (μ F)	Dimensions in mm						dv/dt	Peak Current	Surge Current	ESR 10KHz	ESL	Thermal Res	Irms* 10KHz
	W	H	T	P	P1	ϕ d	V/us	A	A	m Ω	nH	$^{\circ}$ C/W	A 85 $^{\circ}$ C
50	57.5	50.0	35.0	52.5	20.3	1.2	20	1000	3000	6.4	35	7.2	18.0
55	58.0	55.0	45.0	52.5	20.3	1.2	20	1100	3300	5.6	35	6.7	20.0
60	58.0	55.0	45.0	52.5	20.3	1.2	20	1200	3600	4.8	35	6.8	21.5
65	58.0	55.0	45.0	52.5	20.3	1.2	20	1300	3900	4.5	35	6.3	23.0
70	58.0	67.0	45.0	52.5	20.3	1.2	20	1400	4200	4.0	35	6.0	25.0
75	58.0	67.0	45.0	52.5	20.3	1.2	20	1500	4500	3.9	35	5.9	25.5
80	58.0	67.0	45.0	52.5	20.3	1.2	20	1600	4800	3.8	35	5.6	26.5
85	58.0	67.0	45.0	52.5	20.3	1.2	20	1700	5100	3.6	35	5.1	28.5
$U_{OP} = 1100VDC$ at 70 $^{\circ}$ C $U_n = 1000VDC$ at 85 $^{\circ}$ C $U_{OP} = 700VDC$ at 105 $^{\circ}$ C													
1	32.0	18.0	9.0	27.5	NA	0.8	75	75	225	65.0	25	57.7	2.0
2	31.0	22.0	13.0	27.5	NA	0.8	75	150	450	38.0	25	32.2	3.5
3	32.0	25.5	16.0	27.5	NA	0.8	75	225	675	22.0	25	27.3	5.0
4	32.0	30.0	15.0	27.5	NA	0.8	75	300	900	16.5	25	18.6	7.0
5	31.0	33.0	18.0	27.5	NA	0.8	75	375	1125	12.5	25	16.6	8.5
6	31.0	33.0	18.0	27.5	NA	0.8	75	450	1350	11.5	25	16.1	9.0
7	32.0	37.0	22.0	27.5	NA	0.8	75	525	1575	11.0	25	15.1	9.5
7	32.0	37.0	22.0	27.5	10.2	0.8	75	525	1575	9.8	25	11.6	11.5
8	32.0	37.0	22.0	27.5	NA	0.8	75	600	1800	10.5	25	13	10.5
8	32.0	37.0	22.0	27.5	10.2	0.8	75	600	1800	8.8	25	10.1	13.0
5	41.5	30.0	17.0	37.5	NA	1.0	35	175	525	28.0	28	37.1	3.8
6	41.5	30.0	17.0	37.5	NA	1.0	35	210	630	25.0	28	29.6	4.5
7	41.5	30.0	17.0	37.5	NA	1.0	35	245	735	22.0	28	27.3	5.0
8	42.0	33.5	18.5	37.5	NA	1.0	35	280	840	19.5	28	21.4	6.0
10	42.0	40.0	20.0	37.5	10.2	1.0	35	350	1050	13.0	30	20.5	7.5
12	42.5	37.0	22.0	37.5	10.2	1.0	35	420	1260	11.5	30	16.1	9.0
15	42.5	44.0	24.0	37.5	10.2	1.0	35	525	1575	10.0	30	11.3	11.5
18	41.5	45.0	30.0	37.5	20.3	1.0	35	630	1890	7.8	30	9.8	14.0
20	41.5	45.0	30.0	37.5	20.3	1.0	35	700	2100	7.0	30	8.9	15.5
30	57.5	45.0	30.0	52.5	20.3	1.2	20	600	1800	9.8	35	11.6	11.5
35	57.5	45.0	30.0	52.5	20.3	1.2	20	700	2100	8.0	35	10.3	13.5
40	57.5	50.0	35.0	52.5	20.3	1.2	20	800	2400	7.0	35	8.9	15.5
45	58.0	55.0	45.0	52.5	20.3	1.2	20	900	2700	6.2	35	7.9	17.5
50	58.0	55.0	45.0	52.5	20.3	1.2	20	1000	3000	5.8	35	6.8	19.5
55	58.0	55.0	45.0	52.5	20.3	1.2	20	1100	3300	5.0	35	6.8	21.0
60	58.0	67.0	45.0	52.5	20.3	1.2	20	1200	3600	4.6	35	6.2	23.0
65	58.0	67.0	45.0	52.5	20.3	1.2	20	1300	3900	4.2	35	5.7	25.0
70	58.0	67.0	45.0	52.5	20.3	1.2	20	1400	4200	3.8	35	5.4	27.0
$U_{OP} = 1200VDC$ at 70 $^{\circ}$ C $U_n = 1100VDC$ at 85 $^{\circ}$ C $U_{OP} = 770VDC$ at 105 $^{\circ}$ C													
1	32.0	20.0	11.0	27.5	NA	0.8	80	80	240	65.0	25	47.7	2.2
1.5	31.0	22.0	13.0	27.5	NA	0.8	80	120	360	46.0	25	52.2	2.5
2	31.0	25.0	14.0	27.5	NA	0.8	80	160	480	24.5	25	26.6	4.8
3	32.0	30.0	15.0	27.5	NA	0.8	80	240	720	18.5	25	19.2	6.5
4	31.0	33.0	18.0	27.5	NA	0.8	80	320	960	12.5	25	16.6	8.5
5	32.0	37.0	22.0	27.5	NA	0.8	80	400	1200	10.8	25	14.5	9.8
5	32.0	37.0	22.0	27.5	10.2	0.8	80	400	1200	10.5	25	13	10.5

CAP. (μ F)	Dimensions in mm						dv/dt	Peak Current	Surge Current	ESR 10KHz	ESL	Thermal Res	I _{rms} * 10KHz
	W	H	T	P	P1	ϕ d	V/us	A	A	m Ω	nH	$^{\circ}$ C/W	A 85 $^{\circ}$ C
6	32.0	37.0	22.0	27.5	NA	0.8	80	480	1440	10.5	25	13	10.5
6	32.0	37.0	22.0	27.5	10.2	0.8	80	480	1440	8.8	25	10.1	13.0
3	41.5	30.0	17.0	37.5	NA	1.0	40	120	360	46.0	28	52.2	2.5
4	41.5	30.0	17.0	37.5	NA	1.0	40	160	480	32.5	28	37.7	3.5
4.7	42.0	33.5	18.5	37.5	NA	1.0	40	188	564	28.0	28	33.5	4.0
5	42.0	33.5	18.5	37.5	NA	1.0	40	200	600	26.0	28	32.7	4.2
6	42.0	33.5	18.5	37.5	NA	1.0	40	240	720	23.5	28	25.5	5.0
7	42.0	40.0	20.0	37.5	10.2	1.0	40	280	840	18.5	30	22.5	6.0
8	42.5	37.0	22.0	37.5	10.2	1.0	40	320	960	16.5	30	21.5	6.5
9	42.5	37.0	22.0	37.5	10.2	1.0	40	360	1080	13.0	30	20.5	7.5
10	42.5	44.0	24.0	37.5	10.2	1.0	40	400	1200	12.0	30	17.3	8.5
12	42.5	44.0	24.0	37.5	10.2	1.0	40	480	1440	10.8	30	13.9	10.0
14	41.5	45.0	30.0	37.5	20.3	1.0	40	560	1680	9.5	30	11	12.0
15	41.5	45.0	30.0	37.5	20.3	1.0	40	600	1800	8.5	30	10.4	13.0
20	57.5	45.0	30.0	52.5	20.3	1.2	20	400	1200	11.5	35	16.1	9.0
25	57.5	50.0	35.0	52.5	20.3	1.2	20	500	1500	10.0	35	12.4	11.0
30	57.5	50.0	35.0	52.5	20.3	1.2	20	600	1800	8.6	35	10.3	13.0
35	58.0	55.0	45.0	52.5	20.3	1.2	20	700	2100	7.5	35	9.5	14.5
40	58.0	55.0	45.0	52.5	20.3	1.2	20	800	2400	6.8	35	8.6	16.0
45	58.0	55.0	45.0	52.5	20.3	1.2	20	900	2700	6.2	35	7.9	17.5
50	58.0	67.0	45.0	52.5	20.3	1.2	20	1000	3000	5.6	35	7	19.5
55	58.0	67.0	45.0	52.5	20.3	1.2	20	1100	3300	4.8	35	6.8	21.5
U _{OP} = 1300VDC at 70 $^{\circ}$ C U _n = 1200VDC at 85 $^{\circ}$ C U _{OP} = 840VDC at 105 $^{\circ}$ C													
1	32.0	20.0	11.0	27.5	NA	0.8	90	90	270	35.0	25	35	3.5
2	32.0	25.5	16.0	27.5	NA	0.8	90	180	540	24.0	25	25	5.0
3	32.0	30.0	15.0	27.5	NA	0.8	90	270	810	13.0	25	20.5	7.5
4	31.0	33.0	18.0	27.5	NA	0.8	90	360	1080	11.0	25	15.1	9.5
5	32.0	37.0	22.0	27.5	NA	0.8	90	450	1350	10.5	25	13	10.5
5	32.0	37.0	22.0	27.5	10.2	0.8	90	450	1350	9.5	25	11	12.0
3	41.5	30.0	17.0	37.5	NA	1.0	45	135	405	35.0	28	41.9	3.2
4	41.5	30.0	17.0	37.5	NA	1.0	45	180	540	28.0	28	30.4	4.2
5	42.0	33.5	18.5	37.5	NA	1.0	45	225	675	21.5	28	23.1	5.5
6	42.0	40.0	20.0	37.5	10.2	1.0	45	270	810	16.5	30	21.5	6.5
7	42.5	37.0	22.0	37.5	10.2	1.0	45	315	945	13.0	30	20.5	7.5
8	42.5	44.0	24.0	37.5	10.2	1.0	45	360	1080	12.0	30	17.3	8.5
9	42.5	44.0	24.0	37.5	10.2	1.0	45	405	1215	10.8	30	13.9	10.0
10	42.5	44.0	24.0	37.5	10.2	1.0	45	450	1350	10.0	30	12.4	11.0
12	41.5	45.0	30.0	37.5	20.3	1.0	45	540	1620	8.5	30	10.4	13.0
20	57.5	45.0	30.0	52.5	20.3	1.2	25	500	1500	10.0	35	12.4	11.0
25	57.5	50.0	35.0	52.5	20.3	1.2	25	625	1875	8.6	35	10.3	13.0
30	58.0	55.0	45.0	52.5	20.3	1.2	25	750	2250	7.5	35	9.5	14.5
35	58.0	55.0	45.0	52.5	20.3	1.2	25	875	2625	6.8	35	8.6	16.0
40	58.0	67.0	45.0	52.5	20.3	1.2	25	1000	3000	5.5	35	6.8	20.0
45	58.0	67.0	45.0	52.5	20.3	1.2	25	1125	3375	4.8	35	6.2	22.5

(*)Maximum RMS current at 10 kHz, $\theta_{SA} = +15^{\circ}$ C, capacitance tolerance $\pm 5\%$.

GENERAL TECHNICAL DATA

APPLICATIONS	DC Link / DC Filtering
DIELECTRIC	Metallized Polypropylene Film
REFERENCE STANDARD	IEC 61071/EN 61071
CLIMATIC CATEGORY	40/105/56 IEC 60068- 1
OPERATING TEMPERATURE RANGE	-40°C ~ +105°C (85°C ~105°C, decreasing factor 1.25% per °C for Rated Voltage)
PROTECTION	Solvent resistant plastic case UL94V-0 Thermosetting resin sealing UL 94V-0 compliant
INSTALLATION	Any position.
PACKAGING	Packed in cardboard boxes with protection for the terminals.
STORAGE CONDITIONS	Storage time: ≤24 months from the date marked on the label package. Average relative humidity per year ≤70% RH≤85% for 30 days randomly distributed throughout the year. Dew is absent: Temperature: -40°C ~ +85°C
STORAGE LIFE	Product that passed less than 2 years from production, No need reconfirmation.
ROHS COMPLIANCE	Compliant with the restricted substance requirement of Directive 2011/65/EU.
FLAME RETARDANT GRADE	Flame retardant performance accords with horizontal combustion grade HB and vertical combustion grade V-0.
APPLICATION NOTE AND LIMITING CONDITIONS	These capacitors are designed only for DC voltage so should not be used for AC line. The continuous peak voltage shall not exceed the rated DC voltage rating.

CONSTRUCTION

1	DIELECTRIC	Metallized Polypropylene Film & Mono Structure	
2	METAL SPRAY	Sn/Zn Alloy	
3	FILLING	Epoxy Resin (UL 94V-0)	
4	CASE	Plastic Case (UL 94V-0)	
5	LEAD WIRE	Tinned Copper Wire	

MARKING

MANUFACTURER'S SYMBOL	 or CKX	EXAMPLE
TYPE OR SERIES	DMP	
NOMINAL CAPACITANCE	Capacitance in µF	
CAPACITANCE TOLERANCE	J (±5%), K(±10%), M(±20%)	
RATED VOLTAGE (at 85°C)	Un	
STANDARD	IEC61071:2007	
DATE CODE	<u>A</u>	

ELECTRICAL CHARACTERISTICS

VOLTAGE RANGE	450Vdc ~ 1200Vdc
CAPACITANCE RANGE	1.0 μ F ~ 200 μ F
CAPACITANCE TOLERANCE	\pm 5% or \pm 10% or \pm 20% at +25°C
CAPACITANCE	Measuring Frequency at 1 kHz Measuring Voltage: 1 \pm 0.2V
STANDARD ATMOSPHERIC CONDITIONS FOR STATIC TEST	AMBIENT TEMPERATURE: 15°C to 35°C (If there is any doubt on the results, the measurements shall be made at +20 +/- 5°C) RELATIVE HUMIDITY: 45% to 75% (If there is any doubt on the results, the measurements shall be made at 60% to 70 %.) AIR PRESSURE: 86 kPa to 106 kPa.
VOLTAGE BETWEEN TERMINALS U_{TT}	1.5* U_n VDC for 10 seconds (between terminations) @ +25°C \pm 5°C
VOLTAGE BETWEEN TERMINALS AND CASE U_{TC}	3000VAC, 50/60Hz 60s (at +25 +/-5°C)
DIELECTRIC DISSIPATION FACTOR $Tg\delta_0$	$\leq 2 \cdot 10^{-4}$
DISSIPATION FACTOR	≤ 0.002 (0.2%) at 1KHz; C $\leq 20\mu$ F at 25°C ≤ 0.003 (0.3%) at 1KHz; C $> 20\mu$ F at 25°C ≤ 0.004 (0.4%) at 1KHz; C $> 80\mu$ F at 25°C
INSULATION RESISTANCE	RC between leads, IR $\times C \geq 30,000$ s at 100vdc 1minute at +25°C
SELF- INDUCTANCE	<1nH per mm of lead spacing
HOT-SPOT	$\leq 85^\circ\text{C}$
LIFE EXPECTANCY	100,000 hours (U_n , hotspot =85°C)
FAILURE RATE	100 Fit
MAX. ALTITUDE	2000 m
OVERVOLTAGE Apply 110% of rated voltage Apply 115% of rated voltage Apply 120% of rated voltage Apply 130% of rated voltage	Maximum duration within one day 30% of on-load duration 30 mins 5 mins 1 min

ENVIRONMENTAL TEST

SOLDERABILITY	<p>TEST CONDITIONS: Testing Method Per IEC 60068-2-20 Ta Soldering Temperature: +245 ±5°C Immersion Duration: 2 ±0.5 seconds</p> <p>PERFORMANCE: More than 95% of circumferential surface of lead wire shall be covered with new solder.</p>
SOLDERING HEAT RESISTANCE	<p>TEST CONDITIONS: Flow Soldering: Preheat Temperature 100°C ~ 120°C Preheat Duration: 100 seconds Max. Soldering Temperature: +260 ±5°C Immersion Duration: ≤10 seconds Immersion Depth: 1.5 ±0.5 mm from roots.</p> <p>Iron Soldering: Soldering Temperature: +400°C Immersion Duration: ≤3 seconds After test, allow it stay alone for 1.5 ± 0.5 hours at standard temperature and humidity before making measurements.</p> <p>PERFORMANCE: Capacitance Change Rate ($\Delta C/C$): ≤±2% DF change ($\Delta tg\delta$): ≤50*10⁻⁴ at 1 KHz. Insulation Resistance: ≥50% of initial limit</p>
HUMIDITY RESISTANCE	<p>TEST CONDITIONS: Testing method per IEC 60068-2-3 Ca Test Temperature: +40 ±2°C Test Humidity: 90% to 95% R.H. Test Duration: 1344 +24/-0 hours</p> <p>PERFORMANCE: Capacitance Change Rate ($\Delta C/C$): ≤±5% DF change ($\Delta tg\delta$): ≤50*10⁻⁴ at 1 KHz. Insulation Resistance: ≥50% of initial limit</p>
COLD RESISTANCE	<p>TEST CONDITIONS: Test Temperature: -40 ±2°C Test Duration: 2 +1/-0 hours</p> <p>PERFORMANCE: Capacitance Change Rate ($\Delta C/C$): ≤±3% DF change ($\Delta tg\delta$): ≤50*10⁻⁴ at 1 KHz Insulation Resistance: ≥50% of initial limit</p>
DRY HEAT RESISTANCE	<p>TEST CONDITIONS: Test Temperature: +105 ±2°C Test Duration: 16 +1/-0 hours</p> <p>PERFORMANCE: Capacitance Change Rate ($\Delta C/C$): ≤±3% DF change ($\Delta tg\delta$): ≤50*10⁻⁴ at 1 KHz. Insulation Resistance: ≥50% of initial limit</p>

ENVIRONMENTAL TEST

RAPID TEMPERATURE CHANGE	<p>TEST CONDITIONS: Testing method per IEC 68-2-14 Na. Test Temperature Cycle: Total 5 cycles High Temperature: +105 ±5°C Low Temperature: -40 ±5°C 30 min ±10% for each temperature</p> <p>PERFORMANCE: Capacitance Change Rate ($\Delta C/C$): ≤±5% DF change ($\Delta tg\delta$): ≤50*10⁻⁴ at 1 KHz Insulation Resistance: ≥50% of initial limit</p>
--------------------------	--

<p>BUMP</p>	<p>TEST CONDITIONS: Pulse shape: half sine Acceleration: 490 m/s² Duration of pulse: 11 ms PERFORMANCE: No visible damage Capacitance Change Rate ($\Delta C/C$): $\leq \pm 2\%$ DF change ($\Delta \tan \delta$): $\leq 50 \times 10^{-4}$ at 1 KHz Insulation Resistance: $\geq 50\%$ of initial limit</p>
<p>HIGH TEMPERATURE LOADING</p>	<p>TEST CONDITIONS: Testing method per IEC 61071 Test Temperature: $+85 \pm 2^\circ\text{C}$. Apply 130% of rated voltage for 1,000 $\pm 24/0$ hours. Duration: 500 hours 1000 charges and discharges At 1.3 * I peak (maximum respective peak current in continuous operation) PERFORMANCE: Capacitance Change Rate ($\Delta C/C$): $\leq \pm 5\%$ DF change ($\Delta \tan \delta$): $\leq 50 \times 10^{-4}$ at 1 KHz. Insulation Resistance: $\geq 50\%$ of initial limit</p>

SOLDERING PROCESS CONT.

<p>SOLDERING</p>	<p>When soldering a capacitor ,heat in soldering is conducted to the elements of the capacitor from lead wire and an enclosure, and hence it should be noted that soldering under high temperature and a long period may cause deterioration of characteristic or breakdown of capacitors.</p>
<p>SOLDERING</p>	<p>Wave flow soldering Heating temperature: $100^\circ\text{C} \sim 120^\circ\text{C}$ Heating time less than 60 sec Heating temperature: $120^\circ\text{C} \sim 130^\circ\text{C}$ Heating time less than 10 sec When using soldering iron Iron tip temperature less than 350°C Soldering time (sec.) within 3seconds When soldering a capacitor mounted on the board with chip-type components When applying the curing for fixing the components, the duration for which a capacitor is exposed to heat shall be within the permissible time, which changes according to the ambient temperature of the as shown in the annex.</p>

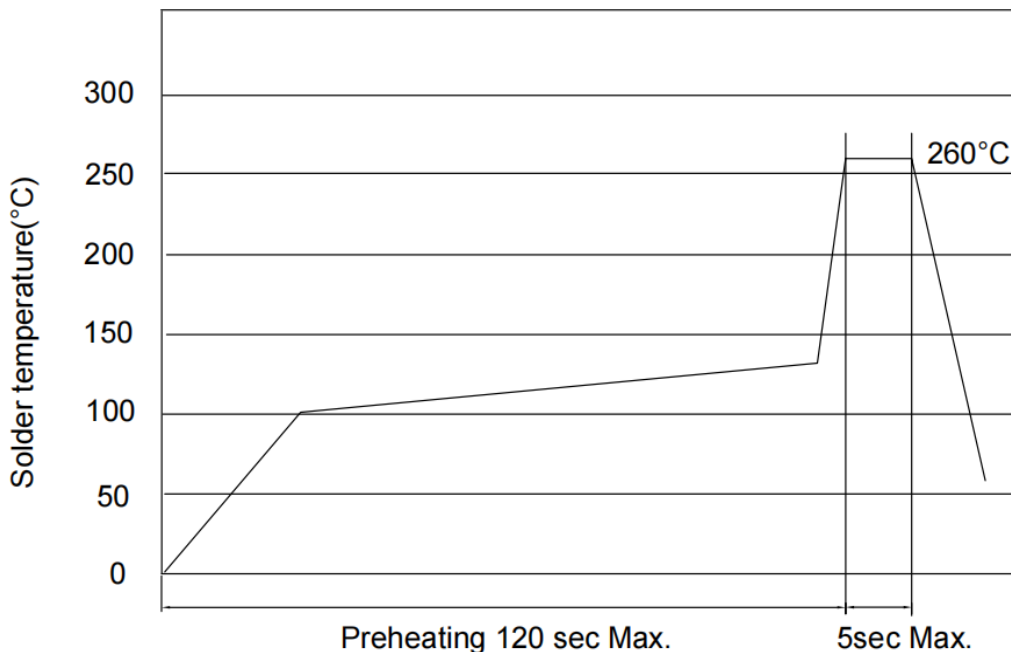

Lifetime Expectancy

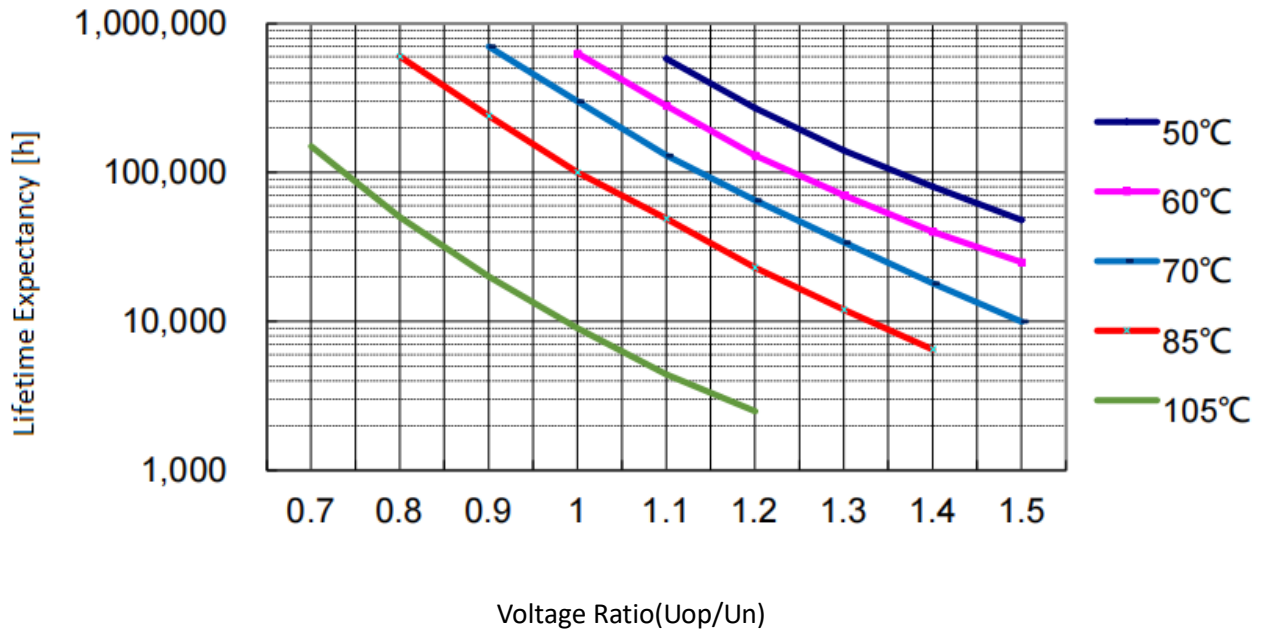

Derating of Rated Voltage Vs Temperature

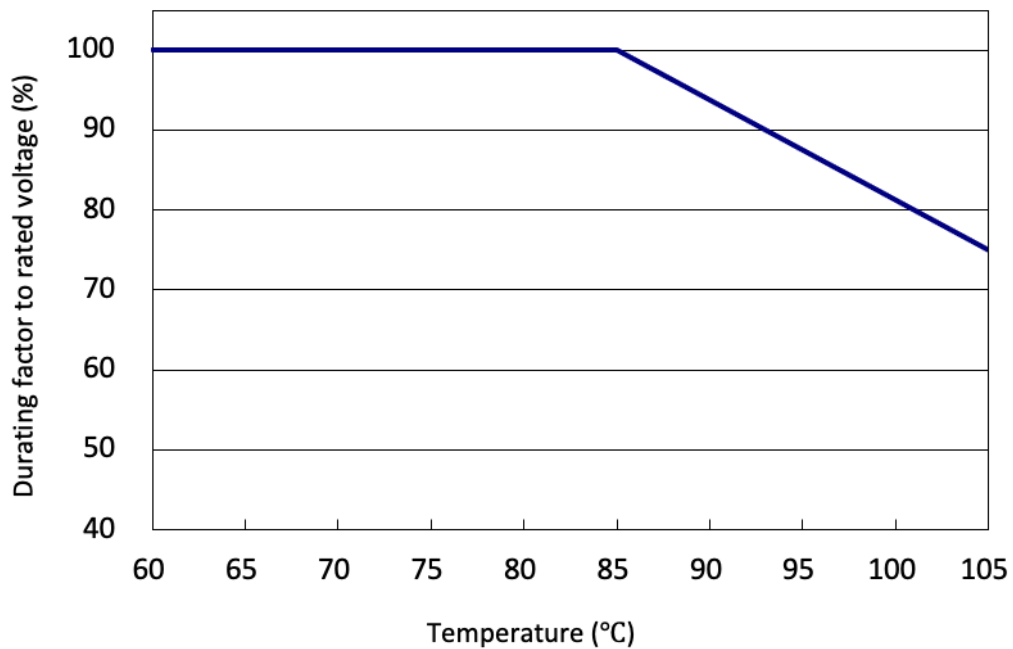

Capacitance Change

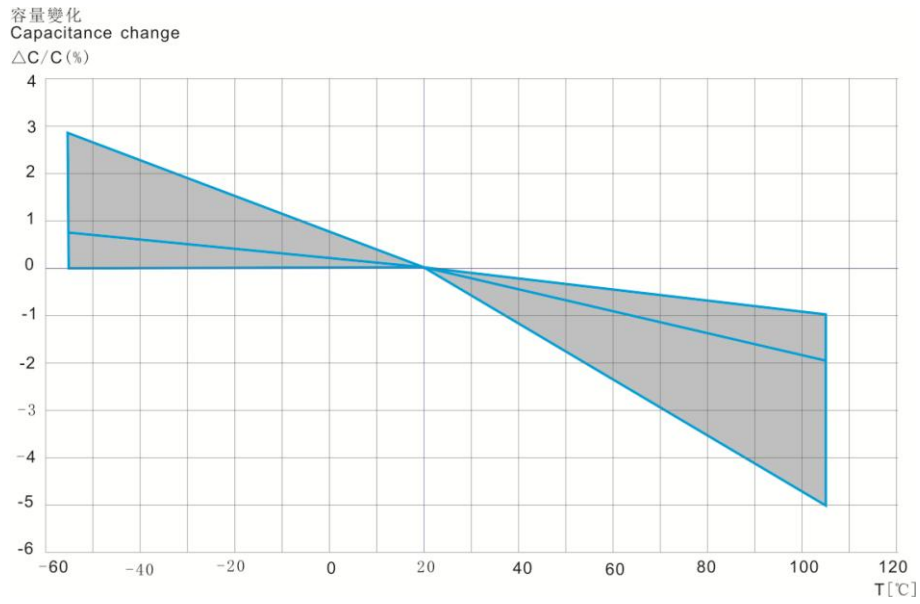

Insulation Resistance

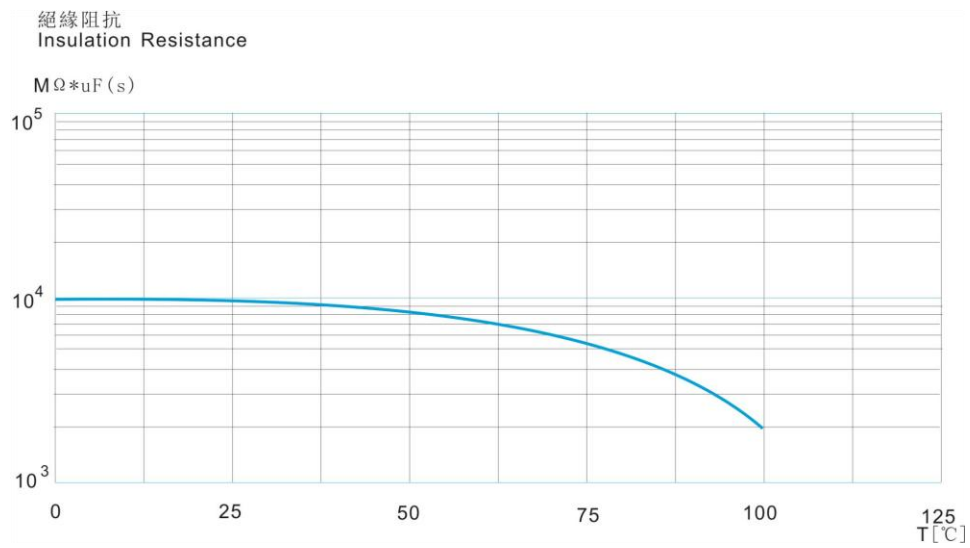

PACKAGING INFORMATION

INNER BOX SPECIFICATIONS (Dimensions in mm)			
BOX #	L ±3	W ±3	H ±3
# 1	331	331	25
# 2	331	331	35
# 3	331	331	50
# 4	331	331	80
# 5	350	170	35
# 6	350	170	50
# 7	350	170	80

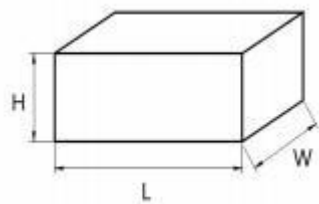

OUTER BOX SPECIFICATIONS (Dimensions in mm)			
BOX #	L ±5	W ±5	H ±5
# 1	350	340	265
# 2	370	360	350

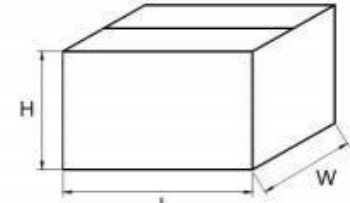

PACKAGING QUANTITY

PITCH	Size Code	W	H	T	SPQ
27.5	E30	32	18	9	340
	E07	32	20	11	280
	E28	31	22	13	230
	E05	31	25	14	230
	E24	32	28	14	220
	E17	32	25.5	16	200
	E22	32	30	15	190
	E15	31	33	18	170
	E06	32	37	22	140
37.5	G15	42	33.5	18.5	112
	G08	42	40	20	105
	G14	42.5	37	22	98
	G10	42.5	44	24	91
	G12	42.5	37	28	77
	G06	41.5	41	27.5	77
	G01	41.5	45	30	70
	G07	41.5	30	17	126
52.5	M02	57.5	45	30	50
	M07	57.5	50	35	45
	M06	57.5	65	35	45
	M03	58	55	45	35
	M05	58	67	45	35