

PRODUCT SPECIFICATION

**PRODUCT: CERAMIC DISC CAPACITOR
SAFETY RECOGNIZED**

TYPE: AC SERIES

CUSTOMER: _____

DOC. NO.: POE-D11-02-E-30

Ver.: 30

APPROVED BY CUSTOMER

VENDOR:

HITANO ENTERPRISE CORP.
7F-7, NO. 3, WU CHUAN 1ST ROAD, NEW
TAIPEI INDUSTRIAL PARK, NEW TAIPEI CITY,
TAIWAN, R.O.C.
TEL: +886 2 2299 1331 (REP.)
FAX: +886 2 2298 2466



MAKER:

PAN OVERSEAS (GUANGZHOU) ELECTRONIC CO.,LTD.
NO.277,HONG MING ROAD,EASTERN SECTION,
GUANG ZHOU ECONOMIC AND TECHNOLOGY
DEVELOPMENT ZONE,CHINA



Record of change

Date	Version	Description	Page
2008.6.3	1	1. C23-00-C-01(before) → POE-C11-00-C-01(1st edition)	
2008.8.22	2	1. Complete lead code	20
		2. Add last SAP code “ H ” for halogen and Pb free , epoxy resin..	3
2008.12.12	3	1. Complete the 13th to 17th codes of SAP P/N.	4
		2. Page layout adjustment.	
2009.7.16	4	1 Change PSA & POE logo to Walsin & POE logo.	9
		2.Complete Marking statement.	11
		3.Revised standard NO. of SEV, SEMKO, FIMKO, NEMKO, DEMKO and KEMA.	
		4.Downsize	
2009.9.14	5	1. “ Protrusion length”: “+0.5 to-1.0” revised to “2.0max (Or the end of lead wire may be inside the tape.)”	9
2009.12.24	6	1. Marking	10
		2. Correct recognized No	11
		3. Revised the Figure of impulse voltage test (Item 7.3.14) according to the standard IEC 60384-14 ed.3	14
2011/1/13	7	1. Review SAP P/N about diameter code:	6
		2. Delete “AT” taping type.	4,5,8,9
		3. Add test item “Temperature Cycle ”.	15
		4. Add item 10 “Drawing of internal structure and material list”	20
2011/4/27	8	1. Add “1AC” type;	4
		2. Delete “old P/N”	6
		3. Define the marking of the type “0AC” and “1AC”;	8
		4. Review the “Standard No. & Subclass & W.V. & Recognized No”.	9
2012/2/7	9	1. Review the “Standard No. & Subclass & W.V. & Recognized No”.	9
		2. Review the “Operating Temperature Range” from “-25 to +125°C” to “-40 to +125°C”	10
		3. Review the temperature of Step 1 from “-25+0/-3” to “-40+0/-3”	14
2012/4/6	10	1. In order to improve the traceability of the product, change the date code on capacitor body, new date code can trace back to production “Lot No.”	8
2013/5/6	11	1. Review the Lead diameter φ from 0.60 +0.1/-0.05mm to 0.55+/-0.05mm	5,6,7
		2. In order the customer to know the round time of manufacture, review the date code on capacitor body, new date code can know the month of manufacture.	8
		3. Delete “No marked with “ _ ” stand for Pb free”. Add “epoxy resin”	8
		4. Review the Solderability time from 2±0.5s to 5±0.5s	11
2013/10/16	12	1. Review the “Manufactured Date” to “Products ID” on the marking page	8
		2. Delete “The marking can be printed on either one side or two side of coating body.”and add “for SAP part number 10-11 digits ≤’07’ products”to two sides and “for SAP part number 11-12 digits ≥’08’ products”to one side.	8
2014/11/5	13	1. Review the terminal position of the lead wire.	8
		2. Review the product of ID, add the code “D” for the products of Dongguan Walsin Technology Electronics Co., Ltd.	9
		3. Review the minimum packing quantity of taping code AM.	16
2014/12/25	14	1. Add“3.1Nominal parts&3.2 special for surge parts” for “3. Part Numbering /T.C./Capacitance/ Tolerance/Diameter”	7
2015/5/27	15	Add the X1:440Vac/Y2:300Vac safety approval for CQC.	4,10
2015/8/4	16	Delete the H(Inside kink lead)	5,8
2015/11/12	17	1. Review the normal parts of Taping type	6,7
		2. Review Marking	9
2016/1/27	18	1. Review the Available lead code of Lead Configuration	5
		2. Revised standard NO. of VDE, SEV, SEMKO, FIMKO, NEMKO, DEMKO and KTL.	10
2016/5/3	19	1. Delete 6 pF~10 pF for P/N CH*AC***D06 * *, 12 pF~15 pF for P/N CH*AC120J06 * *,18 pF~24 pF for P/N CH*AC***J07 * *, 27 pF~33 pF for P/N CH*AC***J08 * *, and 36 pF~39 pF for P/N CH*AC***J09 * *	6
2016/11/1	20	1. Review the Available lead code of Lead Configuration	5
		2. Delete “CH” series.	4,6,11~1
		3. Revised the Marking for 1AC type.	5,20,9

Record of change (continue)

Date	Version	Description	page
2017/6/26	21	1. Revise CQC Standard No.	10
2018/8/11	22	1. Revised standard NO. of VDE, SEV, SEMKO, FIMKO, NEMKO and DEMKO.	10
2019/2/25	23	1. Delete “3.2 Special design parts” for surge withstanding	7
2019/4/24	24	1. “Protrusion length” : “2.0max (Or the end of lead wire may be inside the tape.)” revised to “+0.5to-1.0 (Or the end of lead wire may be inside the tape.)” 2. Add “Soldering Recommendation”	7 18
2019/12/11	25	1. Review the Available lead code of Lead Configuration 2. Add “8.3 Label samples ”	5 14
2021/9/9	26	1. Delete Walsin & POE logo.	1
2022/4/19	27	1. Add Applied voltage in 9.1 Caution (Rating): 2. Add 9.3.4 List of substances that affect the insulation strength of coating	16 18
2023/5/26	28	1. Revised recognized No. of SEMKO and FIMKO.	9
2023/9/25	29	1. Review the bulk packing quantity of the code of 14 th to 15 th ≥ 12	14
2024/7/10	30	1. Revised recognized No. of SEV, SEMKO and FIMKO.	9

Table of Contents

No.	Item	Page
1	Part number for SAP system	4
2	Mechanical	5
3	Part numbering/T.C/Capacitance/ Tolerance/Diameter	6
4	Taping Format	7
5	Marking	8
6	Scope	9
7	Specification and test method	10~13
8	Packing specification	14
9	Notices	15~18
10	Soldering Recommendation	19
11	Drawing of Internal Structure and material list	20

1. Part number for SAP system

(Ex.) **YV 0 AC 472 M 10 0 L 20 C 7 H**
 (1) (2)-1 (2)-2 (3) (4) (5) (6) (7) (8) (9) (10) (11)

(1) Temperature characteristic (identified code)

CODE	Temperature characteristic	Cap. Change
SL	SL	-1000~+350ppm/°C (+20°C~+85°C)
YP	Y5P	±10%
YU	Y5U	-55% to +20%
YV	Y5V	-80% ~ +30%

(2)-1 Rated voltage(identified by 1-figure code): 0 = X1:400Vac/Y2:250Vac; 1 = X1:440Vac/Y2:300Vac

(2)-2 Type(identified by 2-figure code): AC

(3) Capacitance (identified by 3-figure code): EX.221=220pF

(4) Capacitance tolerance (identified by code): J:±5%,K:±10%,M:±20%

(5) Nominal body diameter dimension (identified by 2-figure code) : 06--Dmax7.0mm, 07--Dmax8.0mm...

(6) Internal code: 0--Normal, other code--Special control

(7) Lead Style : Refer to “2. Mechanical”.

(8) Packing mode and lead length (identified by 2-figure code)

Taping Code	Description
AF	Ammo box and product pitch: 15.0 mm
AM	Ammo box and product pitch: 25.4 mm

Bulk Code	Description
03	Lead length: 3.0mm
3E	Lead length: 3.5mm
04	Lead length: 4.0mm
4E	Lead length: 4.5mm
20	Lead length: 20.0mm

(9) Tolerance of lead length

Code	Description
A	±0.5 mm (only for kink lead type) Short lead
B	±1.0 mm Short lead
C	Min. Long lead
D	Taping special purpose Taping

(10) Lead space

Code	Description
7	7.5±1.0 mm
M	7.5±0.5 mm
0	10±1.0 mm
A	10±0.5 mm

(11) Epoxy resin code

Code	Description
B	Halogen and Pb free , epoxy resin.
H	

2. Mechanical

Encapsulation: Epoxy resin, flammability UL94 V-0

Available lead code(unit: mm)

Lead type	SAP P/N (13-17)digits	Lead space (F)	Lead Length (L)	Packing	Lead Configuration
Lead style: L or B Type L or B Straight lead	L03B7	7.5 ± 1.0	3.0 ± 1.0	Bulk	
	L4EB7	7.5 ± 1.0	4.5 ± 1.0		
	L05B7	7.5 ± 1.0	5.0 ± 1.0		
	L03B0	10 ± 1.0	3.0 ± 1.0		
	L4EB0	10 ± 1.0	4.5 ± 1.0		
	L05B0	10 ± 1.0	5.0 ± 1.0		
	L20C7	7.5 ± 1.0	20 min.		
	L20C0	10 ± 1.0	20 min.		
	BAFD7	7.5 ± 1.0	Refer to "4. Taping format"	Tap. Ammo	
	BAMD7	7.5 ± 1.0			
BAMD0	10 ± 1.0				
Lead style: G Type G Straight lead	G03A7	7.5 ± 1.0	3.0 ± 0.5	Bulk	
	G3EA7	7.5 ± 1.0	3.5 ± 0.5		
	G04A7	7.5 ± 1.0	4.0 ± 0.5		
	G03A0	10 ± 1.0	3.0 ± 0.5		
	G3EA0	10 ± 1.0	3.5 ± 0.5		
	G04A0	10 ± 1.0	4.0 ± 0.5		
	GAFD7	7.5 ± 1.0	Refer to "4. Taping format"	Tap. Ammo	
	GAMD7	7.5 ± 1.0			
GAMD0	10 ± 1.0				
Lead style: D Type D Vertical kink lead	D03A7	7.5 ± 1.0	3.0 ± 0.5	Bulk	
	D3EA7	7.5 ± 1.0	3.5 ± 0.5		
	D04A7	7.5 ± 1.0	4.0 ± 0.5		
	D03A0	10 ± 1.0	3.0 ± 0.5		
	D3EA0	10 ± 1.0	3.5 ± 0.5		
	D04A0	10 ± 1.0	4.0 ± 0.5		
	D20C7	7.5 ± 1.0	20 min.		
	D20C0	10 ± 1.0	20 min.		
	DAFD7	7.5 ± 1.0	Refer to "4. Taping format"	Tap. Ammo	
	DAMD7	7.5 ± 1.0			
	DAMD0	10 ± 1.0			
Lead style: X Type X Outside kink lead	X03A7	7.5 ± 1.0	3.0 ± 0.5	Bulk	
	X3EA7	7.5 ± 1.0	3.5 ± 0.5		
	X04A7	7.5 ± 1.0	4.0 ± 0.5		
	X05B7	7.5 ± 1.0	5.0 ± 1.0		
	X03A0	10 ± 1.0	3.0 ± 0.5		
	X3EA0	10 ± 1.0	3.5 ± 0.5		
	X04A0	10 ± 1.0	4.0 ± 0.5		
	X05B0	10 ± 1.0	5.0 ± 1.0		
	XAFD7	7.5 ± 1.0	Refer to "4. Taping format"	Tap. Ammo	
	XAMD7	7.5 ± 1.0			
	XAMD0	10 ± 1.0			

*Lead diameter Φd: 0.55+/-0.05mm

 * **C** (Coating **extension** on leads): 3.0mmMax for straight lead style; Not exceed the kink for kink lead.

3. Part numbering/T.C/Capacitance/ Tolerance/Diameter :

SAP Part. No.	T.C.	Capacitance	Tolerance	Dimensions (unit: mm)				
				D (max)	T (max)	F		φd
						Bulk type	Taping type	
SL*AC***J060*	SL	10,12,15,18,20,22,24,27,30,33,36,39,47,50,51(pF)	±5%	7.0	5.0	7.5±1, 10±1	7.5±1 (AFD7)	0.55+/-0.05
SL*AC***J070*		56,62, 68,75(pF)	±5%	8.0				
SL*AC820J080*		82pF	±5%	9.0				
SL*AC101J090*		100pF	±5%	10.0				
YP*AC101K060*	Y5P	100 pF	±10%	7.0				
YP*AC151K060*		150 pF	±10%	7.0				
YP*AC221K060*		220 pF	±10%	7.0				
YP*AC331K060*		330 pF	±10%	7.0				
YP*AC471K060*		470 pF	±10%	7.0				
YP*AC561K070*		560pF	±10%	8.0				
YP*AC681K070*		680 pF	±10%	8.0				
YP*AC821K080*		820 pF	±10%	9.0				
YP*AC102K080*		1000 pF	±10%	9.0				
YU*AC102M060*		Y5U	1000 pF	±20%			7.0	
YU*AC152M080*			1500 pF	±20%			9.0	
YU*AC222M080*			2200 pF	±20%			9.0	
YU*AC332M100*	3300 pF		±20%	11.0				
YU*AC392M120*	3900 pF		±20%	13.0				
YU*AC472M120*	4700 pF	±20%	13.0					
YV*AC102M060*	Y5V	1000 pF	±20%	7.0				
YV*AC152M060*		1500 pF	±20%	7.0				
YV*AC222M060*		2200 pF	±20%	7.0				
YV*AC332M080*		3300 pF	±20%	9.0				
YV*AC392M100*		3900 pF	±20%	11.0				
YV*AC472M100*		4700 pF	±20%	11.0				
YV*AC682M120*		6800 pF	±20%	13.0				
YV*AC103M140*		10000 pF	±20%	15.0				

4. Taping Format

- 15 mm pitch/lead spacing 7.5mm taping

Lead Code: *BAFD7 & *DAFD7 & *XAFD7 & *GAFD7

- 25.4mm pitch/lead spacing 7.5mm & 10.0mm taping

Lead Code: *BAMD* & *DAMD* & *XAMD* & *GAMD*

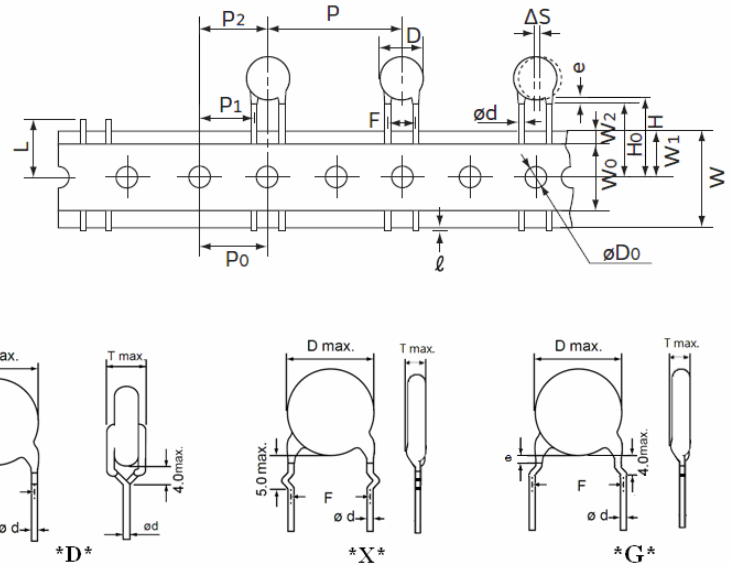
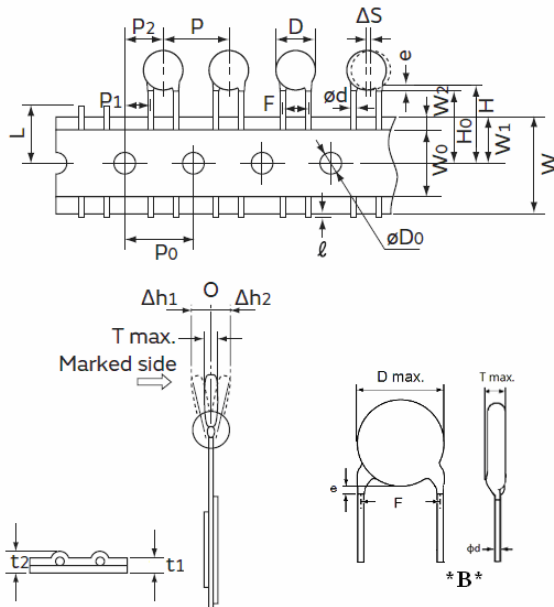

POE Part Number		*BAFD7 / *DAFD7 *XAFD7 / *GAFD7	*BAMD7 / *DAMD7 *XAMD7 / *GAMD7	*BAMD0 / *DAMD0 *XAMD0 / *GAMD0
Item	Symbol	Dimensions (mm)		Dimensions (mm)
Pitch of component	P	15.0±1.0		25.4±2.0
Pitch of sprocket	P0	15.0±0.3		12.7±0.3
Lead spacing	F	7.5±1.0		10.0±1.0
Length from hole center to component center	P2	7.5±1.5		12.7 ± 1.5
Length from hole center to lead	P1	3.75±1.0		7.7±1.5
Body diameter	D	See the “3. Part numbering/T.C/Capacitance/ Tolerance/Diameter”		
Deviation along tape, left or right	Δ S	0±2.0		
Carrier tape width	W	18.0 +1/-0.5		
Position of sprocket hole	W1	9.0±0.5		
Lead distance between the kink and center of sprocket hole	H0	18.0+2.0/-0 (For: *DAFD7 / *XAFD7/ *GAFD7)	18.0+2.0/-0 (For: *DAMD7 / *XAMD7 / *GAMD7)	18.0+2.0/-0 (For: *DAMD0 / *XAMD0 / *GAMD0)
Lead distance between the bottom of body and the center of sprocket hole	H	20.0+1.5/-1.0 (For: *BAFD7)	20.0+1.5/-1.0 (For: *BAMD7)	20.0+1.5/-1.0 (For: *BAMD0)
Length from the terminal of the lead wire to the edge of carrier tape	ℓ	+0.5 to -1.0 (Or the end of lead wire may be inside the hole-down tape.)		
Diameter of sprocket hole	D0	4.0±0.2		
Lead diameter	φd	0.55±0.05		
Total tape thickness	t1	0.6±0.3		
Total thickness, tape and lead wire	t2	1.5 max.		
Deviation across tape	Δ h1/Δ h2	2.0 max.		
Portion to cut in case of defect	L	11.0 max.		
Hole-down tape width	W0	8.0 min		
Hole-down tape distortion	W2	1.5±1.5		
Coating extension on leads	e	3.0 max for straight lead style; Not exceed the kink leads for kink lead.		
Body thickness	T	See the “3. Part numbering/T.C/Capacitance/ Tolerance/Diameter”		

6. Scope

THIS SPECIFICATION APPLIES TO CERAMIC INSULATED CAPACITORS DISK TYPE USED IN ELECTRONIC EQUIPMENT.

- VDE/SEV/SEMKO/FIMKO/NEMKO/DEMKO/ UL/CSA recognized capacitor for Antenna coupling and AC line-by-pass.X1, Y2 Capacitor based on IEC 60384-14
“UL, CSA recognized for across-the-line, line-by-pass” and antenna-isolation.

2.Approval Standard and Recognized No.

Safety Standard	Standard No.	Subclass	w.v.	Recognized No.
UL	ANSI/UL 60384-14:2013	X1	400VAC or 440VAC	E146544
		Y2	250VAC or 300VAC	
CSA	CAN/CSA-E60384-14:14	X1	400VAC or 440VAC	2347969
		Y2	250VAC or 300VAC	
VDE (ENEC)	EN 60384-14:2013/A1:2016 IEC 6.384-14:2013 IEC 6.384-14:2013/AMD1:2016	X1	400VAC or 440VAC	40001829
		Y2	250VAC or 300VAC	
SEV	EN 60384-14:2013 + A1:16	X1	400VAC or 440VAC	24.0417
		Y2	250VAC or 300VAC	
SEMKO	EN 60384-14:2013+A1	X1	400VAC or 440VAC	SE-S-1811994R3
		Y2	250VAC or 300VAC	
FIMKO	EN 60384-14:2013 + A1:16	X1	400VAC or 440VAC	FI/41696-A3
		Y2	250VAC or 300VAC	
NEMKO	EN 60384-14:2013;A1	X1	400VAC or 440VAC	P18222947
		Y2	250VAC or 300VAC	
DEMKO	EN 60384-14:2013/A1:2016 EN 60384-14:2013	X1	400VAC or 440VAC	D-07617
		Y2	250VAC or 300VAC	
CQC	GB/T6346.14-2015	X1:400VAC /Y2:250VAC		CQC08001026519
	IEC60384-14:2013	X1: 440VAC /Y2:300VAC		CQC15001121984
KC	K60384-14 2006	X1	400VAC or 440VAC	SU03065-14001A
		Y2	250VAC	SU03065-14002A
		Y2	300VAC	SU03065-14003A

7. Specification and test method

7.1 Operating Temperature Range :
-40 to +125°C

7.2 Test condition:

Test and measurement shall be made at the standard condition. (temperature 15~35°C, relative humidity 45~75% and atmospheric pressure 860~1060hpa). Unless otherwise specified herein.

If doubt occurred on the value of measurement, and measurement was requested by customer capacitors shall be measured at the reference condition. (temperature 20±2°C or 25 ± 2°C, relative humidity 60~70% and atmospheric pressure 860~1060hpa.)

7.3 Performance:

Item		Specification	Testing Method												
1	Appearance and Dimension	No visible defect, and dimensions are within specified range.	The capacitor should be visually inspected for evidence of defect. Dimensions should be measured with slide calipers.												
2	Marking	To be easily legible.	The capacitor should be visually inspected.												
3	Between lead wires	No failure.	The capacitors shall not be damage when AC2600V(rms.) are applied between the lead wires for 60 sec. (Charge/Discharge current ≤ 50mA.) Pre-treatment: Capacitor shall be stored at 125±2°C for 1hour.then placed at ※ ¹ room condition for 24±2hours before initial measurements.												
	Body Insulation	No failure.	First the terminal of capacitor shall be connected together. Then a metal foil shall be closely wrapped around the body of the capacitor distance of about 3 to 6 mm from each terminal. Then the capacitor shall be inserted into a container filled with metal balls of about 1 mm diameter. Finally, AC2600V(rms.) is applied for 60 sec. between the capacitor lead wires and metal balls. (Charge/Discharge current ≤ 50mA.) Pre-treatment: Capacitor shall be stored at 125±2°C for 1hour.then placed at ※ ¹ room condition for 24±2hours before initial measurements.												
4	Insulation Resistance(I.R.)	10000MΩ min.	The insulation resistance shall be measured with 500±50VDC with 60±5sec. of charging. Pre-treatment: Capacitor shall be stored at 125±2°C for 1hour.then placed at ※ ¹ room condition for 24±2hours before initial measurements.												
5	Capacitance	Within specified tolerance	Y5P&Y5U&Y5V: The capacitance shall be measured at 20±2°C with 1kHz±20% and 1.0Vrms. SL: The capacitance shall be measured at 25°C with 1MHz±20% and 1.0Vrms												
6	Dissipation Factor(D.F.) or Q	Char. Specification	Pre-treatment: Capacitor shall be stored at 125±2°C for 1hour.then placed at ※ ¹ room condition for 24±2hours before initial measurements.												
		Y5P D.F. ≤ 2.5%													
	Y5U D.F. ≤ 5.0%														
	SL Q: ≥ 1000 (C ≥ 30pF) Q: ≥ 400+20×C (C < 30Pf)														
7	Temperature Characteristic	Char. Capacitance Change	The capacitance measurement shall be made at each step specified in table. <table border="1" data-bbox="790 1836 1364 1904"> <tr> <th>Step</th> <th>1</th> <th>2</th> <th>3</th> <th>4</th> <th>5</th> </tr> <tr> <th>Temp.(°C)</th> <td>+20±2</td> <td>-25±2</td> <td>+20±2</td> <td>+85±2</td> <td>+20±2</td> </tr> </table> Pr-treatment : Capacitor shall be stored at 125±2°C for 1 hour. Then placed at room condition for 1(※)24±2 hours before measurement	Step	1	2	3	4	5	Temp.(°C)	+20±2	-25±2	+20±2	+85±2	+20±2
		Step		1	2	3	4	5							
		Temp.(°C)		+20±2	-25±2	+20±2	+85±2	+20±2							
		Y5P Within ± 10%													
Y5U Within ± $\frac{20}{55}$ %															
Y5V Within -80 ~ +30%															
SL -1000~+350 ppm/°C (+20°C ~ +85°C)															

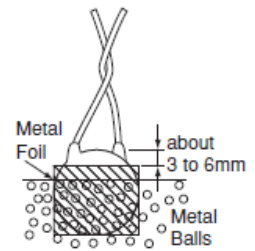

※ "room condition" temperature : 15~35°C, humidity : 45~75%,atmospheric pressure : 86~106kPa

※ "C" expresses nominal capacitance value (pF).

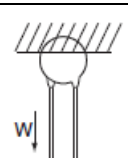
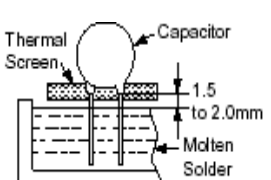
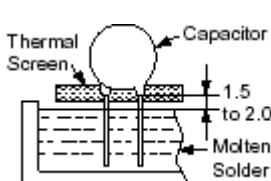
Item		Specification	Testing Method	
8	Robustness of Termination	Tensile Lead wire shall not cut off capacitor shall not be broken.	As shown in the figure at right, fix the body of the capacitor and apply a tensile weight gradually to each lead wire in the radial direction of the capacitor up to 10N and keep it for 10±1 sec. 	
		Bending Lead wire shall not cut off capacitor shall not be broken.	W Each lead wire should be subjected to 5N of weight and bent 90° at the point of egress, in one direction, then returned to its original position and bent 90° in the opposite direction at the rate of one bend in 2 to 3 sec.	
9	Solderability of leads	Lead wire should be soldered with uniform coating on the axial direction over 3/4 of the circumferential direction.	The lead wire of capacitor should be dipped into molten solder for 5 ± 0.5 sec. The depth of immersion is up to about 1.5 to 2.0 mm from the root of lead wires. Temp. of solder : Lead free solder (Sn-3Ag -0.5Cu) 245 ± 5 °C	
10	Soldering Effect (Non-Preheat)	Appearance	No marked defect	
		I.R.	1000MΩ min.	
		Dielectric Strength	Per Item 3.	
		Capacitance Change	Y5P,Y5U,Y5V : Within ±10% SL : Within±2.5% or ±0.25pF,Whichever is large.	
	Soldering Effect (On-Preheat)	Appearance	No marked defect.	As shown in figure, the lead wires should be immersed in solder of 350 ± 10 °C or 260 ± 5 °C up to 1.5 to 2.0mm from the root of Terminal for 3.5 ± 0.5 sec (10 ± 1 sec for 260± 5 °C)  Pre-treatment: Capacitor shall be stored at 125±2°C for 1hour.then placed at *1room condition for 24±2hours before initial measurements. Post-treatment: Capacitor shall be stored for 1 to 2hours at *1room condition.
		I.R.	1000MΩ min.	
		Dielectric Strength	Per Item 3.	
		Capacitance Change	Y5P,Y5U,Y5V : Within ±10% SL : Within±2.5% or ±0.25pF,Whichever is large.	
Soldering Effect (On-Preheat)	Appearance	No marked defect.	First the capacitor should be stored at 120 + 0 / -5 °C for 60 + 0 / -5sec. Then, as in figure , the lead wires should be immersed solder of 260 + / -5 °C up to 1.5 to 2.0 mm from the root of terminal for 7.5 +0 / -1 sec.  Pre-treatment: Capacitor shall be stored at 125±2°C for 1hour.then placed at *1room condition for 24±2hours before initial measurements. Post-treatment: Capacitor shall be stored for 1 to 2hours at *1room condition.	
	I.R.	1000MΩ min.		
	Dielectric Strength	Per Item 3.		
	Capacitance Change	Y5P,Y5U,Y5V : Within ±10% SL : Within±2.5% or ±0.25pF,Whichever is large.		

※ "room condition" temperature : 15~35°C, humidity : 45~75%,atmospheric pressure : 86~106kPa
 ※ "C" expresses nominal capacitance value (pF).

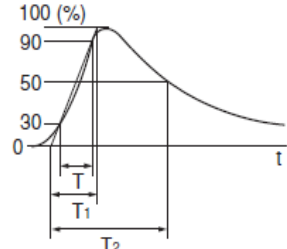
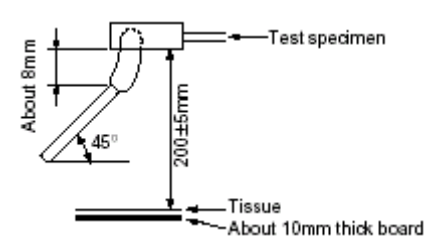
Item		Specification	Testing Method
11	Humidity (Under Steady State)	Appearance	No marked defect.
		Capacitance Change	Y5P : Within ±10% Y5U : Within ±20% Y5V : Within ±30% SL : Within±2.5% or ±0.25pF, Whichever is large.
12	Humidity Loading	D.F.	Y5P,Y5U : 5.0% max. Y5V : 7.5% max.
		Q	SL : $Q \geq 200$ ($C \geq 30\text{pF}$) $Q \geq 100 + 10 \times C/3$ ($C < 30\text{pF}$)
		I.R.	Y5P,Y5U,Y5V : 3000MΩ min. SL : 1000MΩ min.
13	Life	Appearance	No marked defect.
		Capacitance Change	Y5P,Y5U,Y5V : Within ±20% SL : Within±3% or ±0.3pF, Whichever is large.
		I.R.	Y5P,Y5U,Y5V : 3000MΩ min. SL : 1000MΩ min.
		Dielectric Strength	Per Item 3.
14	Passive Flammability	The burning time shall not be exceeded the time 30 sec. The tissue paper shall not ignite.	<p>Impulse Voltage: Each individual capacitor shall be subjected to a 5kv impulses for three times. After the capacitors are applied to life test.</p>  <p>Front time (T_1) = $1.2\mu\text{s} = 1.67T$ Time to half-value (T_2) = $50\mu\text{s}$</p> <p>Fig. The specimen capacitors are placed in a circulating air oven for a period of 1000 hrs. The air in the oven is maintained at a temperature of $125 \pm 2^\circ\text{C}$. Throughout the test. The capacitors are subjected to an AC425Vrms.(for 0AC type) or AC510Vrms.(for 1AC type) alternating voltage of mains frequency.</p> <p>Pre-treatment: Capacitor shall be stored at $125 \pm 2^\circ\text{C}$ for 1hour.then placed at *¹room condition for 24 ± 2hours before initial measurements.</p> <p>Post-treatment: Capacitor shall be stored for 1 to 2hours at *¹room condition.</p> <p>The capacitor under test shall be held in the flame in the position, which best promotes burning. Each specimen shall only be exposed once to the flame. Time of exposure to flame : 30 sec Length of flame : 12 ± 1 mm Gas burner : Length 35 mm min. Inside Dia. : 0.5 ± 0.1 mm Outside Dia. : 0.9 mm max. Gas : Butane gas Purity 95% min.</p> 

※ "room condition" temperature : 15~35°C, humidity : 45~75%,atmospheric pressure : 86~106kPa
 ※ "C" expresses nominal capacitance value (pF).

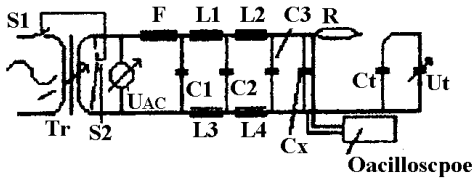
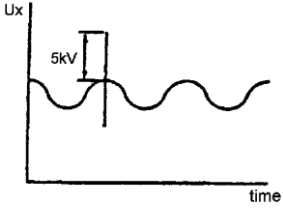
Item	Specification	Testing Method																																							
15	<p>Active Flammability</p> <p>The cheesecloth shall not be on fire.</p>	<p>The specimens shall be individually wrapped in at least one but more than two complete layers of cheesecloth. The specimens shall be subjected to 20 discharges. The interval between successive discharges shall be 5sec. The Uac shall be maintained for 2 min. after the last discharge.</p> <p>Fig.</p>  <p>C1,2 : 1Mf±10% C3 : 0.03Mf±5% 10KV L1-4 : 1.5Mh±20% 16A Rod core choke R : 100Ω±2% Ct : 3Mf±5% 10KV Uac : Ur±5% Ur : Rated working voltage Cx : Capacitor F : Fuse, Rated 10A Ut : Voltage applied to Ct</p> 																																							
16	<table border="1" data-bbox="357 1099 767 1429"> <tr> <td colspan="2">Appearance</td> <td>No marked defect</td> </tr> <tr> <td>Char.</td> <td>Cap. Change</td> <td>DF / Q</td> </tr> <tr> <td>SL</td> <td>≤±5%</td> <td>Q ≥ 275+5/2C (C < 30pF) Q ≥ 350 (C ≥ 30pF)</td> </tr> <tr> <td>Y5P</td> <td>≤±10%</td> <td>DF ≤ 5.0%</td> </tr> <tr> <td>Y5U</td> <td>≤±20%</td> <td>DF ≤ 7.5%</td> </tr> <tr> <td>Y5V</td> <td></td> <td></td> </tr> <tr> <td colspan="2">I.R.</td> <td>3000MΩ min.</td> </tr> <tr> <td colspan="2">Dielectric strength</td> <td>Per Item 3</td> </tr> </table>	Appearance		No marked defect	Char.	Cap. Change	DF / Q	SL	≤±5%	Q ≥ 275+5/2C (C < 30pF) Q ≥ 350 (C ≥ 30pF)	Y5P	≤±10%	DF ≤ 5.0%	Y5U	≤±20%	DF ≤ 7.5%	Y5V			I.R.		3000MΩ min.	Dielectric strength		Per Item 3	<p>The capacitor should be subjected to 5 temperature cycles,</p> <p><Temperature Cycle time: 5 cycles></p> <table border="1" data-bbox="948 1178 1321 1424"> <thead> <tr> <th>Step</th> <th>Temperature(°C)</th> <th>Time(min)</th> </tr> </thead> <tbody> <tr> <td>1</td> <td>-40+0/-3</td> <td>30</td> </tr> <tr> <td>2</td> <td>Room temp.</td> <td>3</td> </tr> <tr> <td>3</td> <td>125+3/-0</td> <td>30</td> </tr> <tr> <td>4</td> <td>Room temp.</td> <td>3</td> </tr> </tbody> </table> <p>Pre-treatment: Capacitor shall be stored at 125±2°C for 1hour.then placed at^{**1}room condition for 24±2hours.</p> <p>Post-treatment: Capacitor shall be stored for 1 to 2hours at ^{**1}room condition.</p>	Step	Temperature(°C)	Time(min)	1	-40+0/-3	30	2	Room temp.	3	3	125+3/-0	30	4	Room temp.	3
Appearance		No marked defect																																							
Char.	Cap. Change	DF / Q																																							
SL	≤±5%	Q ≥ 275+5/2C (C < 30pF) Q ≥ 350 (C ≥ 30pF)																																							
Y5P	≤±10%	DF ≤ 5.0%																																							
Y5U	≤±20%	DF ≤ 7.5%																																							
Y5V																																									
I.R.		3000MΩ min.																																							
Dielectric strength		Per Item 3																																							
Step	Temperature(°C)	Time(min)																																							
1	-40+0/-3	30																																							
2	Room temp.	3																																							
3	125+3/-0	30																																							
4	Room temp.	3																																							

※ "room condition" temperature : 15~35°C, humidity : 45~75%,atmospheric pressure : 86~106kPa
 ※ "C" expresses nominal capacitance value (pF).

8. Packing specification :

8.1 Packing size:

Type	Box	Carton
Bulk		
Ammo taping		

8.2 Packing quantity:

Packing type	The code of 14th to15th in SAP P/N	MPQ(Kpcs/Box)
Taping	AF	1
	AM (The size code ≤ 11)	1
	AM (The size code ≥ 12)	0.5

Packing type	Lead length	Size code of 10th to 11th in SAP P/N	MPQ (Kpcs/Bag)	Kpcs/Box
Bulk	Long lead ($L \geq 20\text{mm}$)	06~12	0.5	1.5
		13-14	0.5	1
	Short lead ($L < 20\text{mm}$)	06~12	0.5	2
		13-14	0.5	1.5

8.3 Label samples:

<p>CUST P/N: NEW POE P/N: YV0AC222M060BAFD7B QTY:1000 PCS POE P/N: YV0AC222M060BAFD7B CAP:2200pF TOL: + -20% VOLT:X1:400VAC, Y2:250VAC T.C: Y5V LOT NO.: 741HB01087 DATE:2018.04.02 PAN OVERSEAS(GUANGZHOU) ELECTRONIC CO.,LTD. R001</p>	
--	--

9. Notices:

9.1 Caution(Rating):

(1). Operating Voltage

Be sure to maintain the V_{p-p} value of the applied voltage or the V_{0-p} which contains DC bias within the rated voltage range.

When the voltage is started to apply to the circuit or it is stopped applying, the irregular voltage may be generated for a transit period because of resonance or switching. Be sure to use a capacitor within rated voltage containing this irregular voltage.

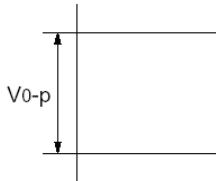
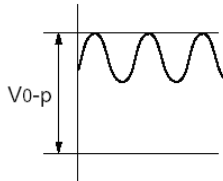
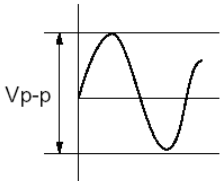
Voltage	DC Voltage	DC+AC Voltage	AC Voltage
Positional measurement			

(2). Operating Temperature and Self-generated Heat

Keep the surface temperature of a capacitor below the upper limit of its rated operating temperature range. Be sure to take into account the heat generated by the capacitor itself.

(3). Test condition for withstanding Voltage

I. Test Equipment

Test equipment for AC withstanding voltage shall be used with the performance of the wave similar to 50/60 Hz sine waves.

If the distorted sine wave or over load exceeding the specified voltage value is applied, the defective may be caused.

II. Voltage Applied Method

When the withstanding voltage is applied, capacitor's lead or terminal shall be firmly connected to the output of the withstanding voltage test equipment, and then the voltage shall be raised from near zero to the test voltage.

If the test voltage without the raise from near zero voltage would be applied directly to capacitor, test voltage should be applied with the *zero cross. At the end of the test time, the test voltage shall be reduced to near zero, and then capacitor's lead or terminal shall be taken off the output of the withstanding voltage test equipment.

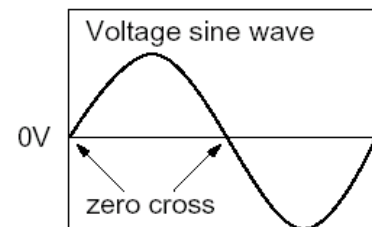

If the test voltage without the raise from near zero

voltage would be applied directly to capacitor, the surge voltage may arise, and therefore, the defective may be caused.

ZERO CROSS is the point where voltage sine wave pass 0V.- See the right figure.

III. Applied voltage

The voltages of Table shall be applied between the respective measuring points of 1 min for qualification approval and periodic testing and for a period of not less than 1 s for lot-by-lot quality conformance testing, a voltage proof test such as Test C shall be carried out only for qualification approval tests and periodic tests;

Attention is drawn to the fact that repetition of the voltage proof test by the user may damage the capacitor. If repetition of the voltage proof test is made by the user, the applied voltage should not be greater than 66 % of the test voltage specified in Table .

Table –Voltage proof

Class	Range of rated voltages	Test A	Test B or Test C
X1	$\leq 1\ 000\ V$	4,3 UR (d.c.) c	2 UR + 1 500 V (a.c.) with a minimum of 2 000 V (a.c.) a
Y2	$\geq 150\ V$ $\leq 500\ V$	UR + 1 200 V (a.c.) with a minimum of 1 500 V (a.c.) b	2 UR + 1 500 V (a.c.) with a minimum of 2 000 V (a.c.) b

a For Delta and T-connected capacitor units according to Figures 5b and 5c, the test voltage for terminals to case shall be the appropriate test voltage for the Y-capacitors.

b For lot-by-lot tests of Class Y2 capacitors, the a.c. test voltage may be replaced by a d.c. voltage of 1,5 times the prescribed a.c. voltage.

c The UR in this d.c. test is the rated a.c. voltage value.

Note:

Test A – Between terminations

Test B – Internal insulation

Test C – External insulation (applicable only to insulated capacitors in nonmetallic case or in insulated metal case)

Figure 5b – Delta by-pass capacitor (in metallic housing)

Figure 5c – Example of a T-connected by-pass capacitor (in non-metallic housing)

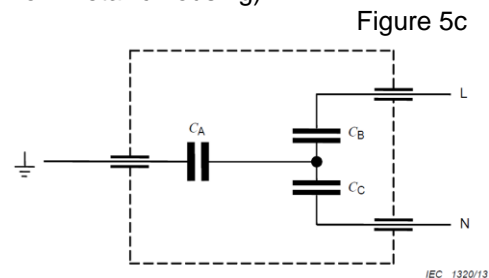
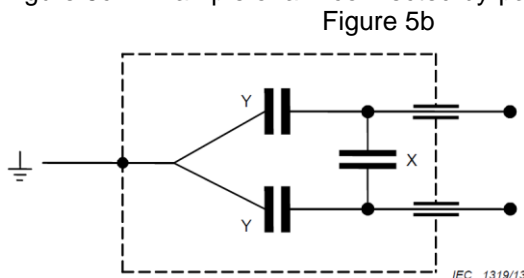

***For capacitors with non-metallic housings, the earth connection is brought out as a separate termination as is shown in Figure 5c.**

(4). Fail-Safe

When capacitor would be broken, failure may result in a short circuit. Be sure to provide an appropriate fail-safe function like a fuse on your product if failure would follow an electric shock, fire or fume.

Failure to follow the above cautions may result, worst case, in a short circuit and cause fuming or partial dispersion when the product is used.

9.2 Caution (Storage and operating condition):

Operating and storage environment

The insulating coating of capacitors does not form a perfect seal; therefore, do not use or store capacitors in a corrosive atmosphere, especially where chloride gas, sulfide gas, acid, alkali, salt or the like are present. And avoid exposure to moisture. Before cleaning, bonding, or molding this product, verify that these processes do not affect product quality by testing the performance of a cleaned, bonded or molded product in the intended equipment. Store the capacitors where the temperature and relative humidity do not exceed -10 to 40 degrees centigrade and 15 to 85 % for 6 months maximum and use within the period after receiving the capacitors.

"Failure to follow the above cautions may result, worst case, in a short circuit and cause fuming or partial dispersion when the product is used."

9.3 Caution (Soldering and Mounting):

9.3.1 Vibration and impact:

Do not expose a capacitor or its leads to excessive shock or vibration during use.

9.3.2 Soldering:

When soldering this product to a PCB/PWB, do not exceed the solder heat resistance specification of the capacitor. Subjecting this product to excessive heating could melt the internal junction solder and may result in thermal shocks that can crack the ceramic element.

When soldering capacitor with a soldering iron, it should be performed in following conditions.

Temperature of iron-tip: 400 degrees C. max.

Soldering iron wattage: 50W max.

Soldering time: 3.5 sec. max.

9.3.3 Cleaning (ultrasonic cleaning):

To perform ultrasonic cleaning, observe the following conditions.

Rinse bath capacity: Output of 20 watts per liter or less.

Rinsing time: 5 min maximum.

Do not vibrate the PCB/PWB directly.

Excessive ultrasonic cleaning may lead to fatigue destruction of the lead wires.

"Failure to follow the above cautions may result, worst case, in a short circuit and cause fuming or partial dispersion when the product is used."

9.3.4 List of substances that affect the insulation strength of coating :

Epoxy resin solvent

Category	Model		
Ketone	Acetone	Butanone	Cyclohexanone
Esters	Ethyl acetate	Dibutyl phthalate	
Chlorinated hydrocarbons	Dichloromethane		

Epoxy resin thinner

Category		Model	
Reactive diluentactivated thinner	Simple function group	HK-66 (Alkyl glycidyl ether)	
		501 (Butyl glycidyl ether)	
		690 (Phenyl Glycidyl Ether)	
		AGE (C12-14Aliphatic Polyalcohol Glycidyl Ether)	
		692 (Benzyl Glycidyl Ether)	
	Two functional groups	D-678 (Neopentyl glycol diglycidyl ether)	
		622 (1,4-Butanediol diglycidyl ether)	
		669 (Ethylene glycol diglycidyl ether)	
		X-632 (Polypropylene glycol diglycidyl ether)	
		X-652 (1,6-Hexadiol diglycidyl ether)	
		D-691Epoxypropane o-methylphenyl ether	
Non-activated thinner	Anhydrous ethanol	Toluene	
	Ethyl acetate	Dimethylbenzene	
	Dimethyl formamide	Butyl acetate	
	Acetone	Styrene	
	Polyol	Benzyl alcohol	

Note: The above substances should not contact the coating of the product body, otherwise it will affect the insulation strength of the product

9.4 Caution (Handling):

Vibration and impact

Do not expose a capacitor or its leads to excessive shock or vibration during use.

"Failure to follow the above cautions may result, worst case, in a short circuit and cause fuming or partial dispersion when the product is used."

10. Soldering Recommendation:

10.1 Wave Soldering Profile:

- Temperature conditions of the flow is recommended as shown in the chart
- Must implement the pre-heat
- Maximum peak flow temperature is recommended 265°C
- Time “ T ” implement in the chart recommended within 20 sec. it temperature exceed 200°C
- Take care with the flow solder not to touch the capacitor body directly at mounting

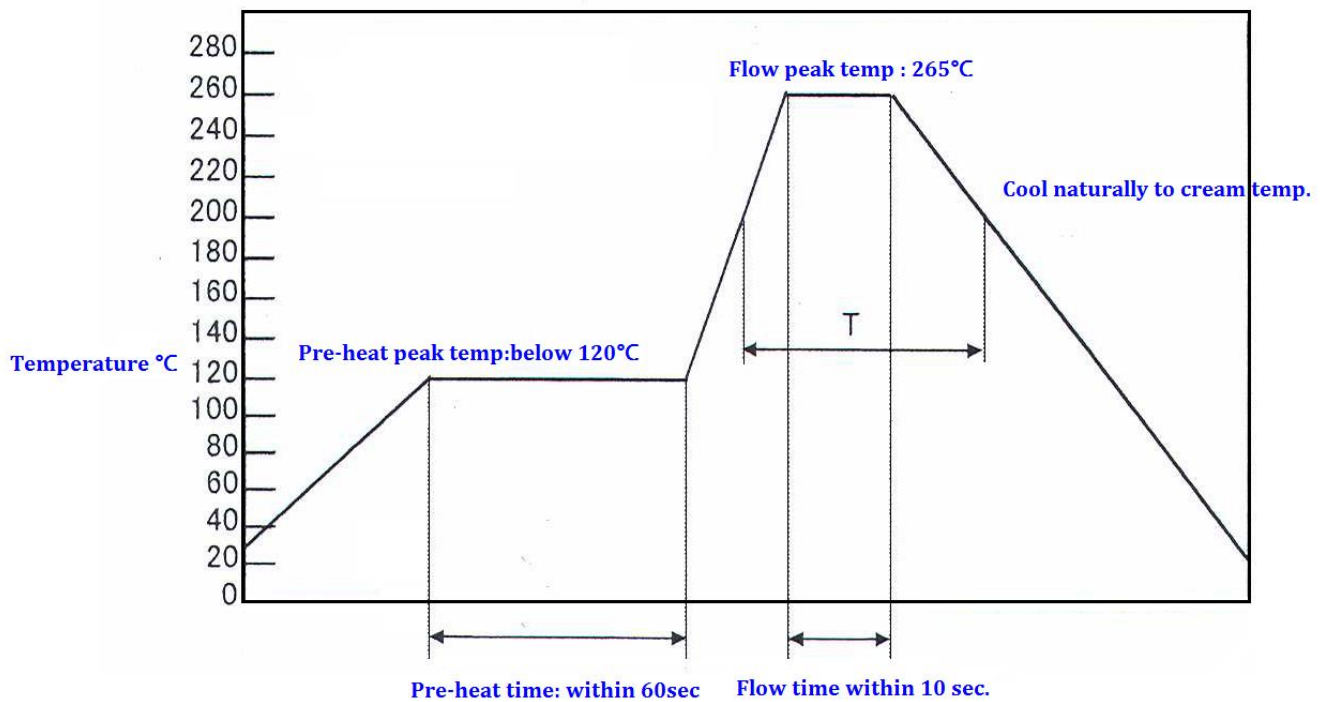

Chart to show flow recommended temp

10.2 Recommended Reworking Conditions with Soldering Iron :

- Temperature of iron-tip: 400 degrees C. max.
- Soldering iron wattage: 50W max.
- Soldering time: 3.5 sec. max.
- Distance from coating body: 2 mm (min.)

10.3 Reflow-Soldering : Lead Ceramic Cap. should not be soldered by reflow-soldering.

11. Drawing of internal structure and material list :

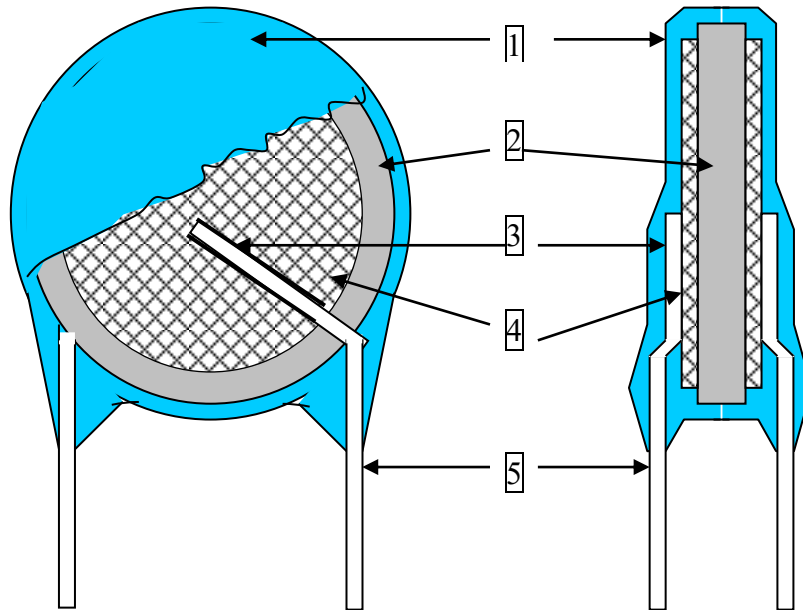

Remarks :

No.	Part name	Material	Model/Type	Component
1	Insulation Coating	Epoxy polymer	EF-150 PCE-300 ECP-357	Epoxy resin、 Pigment (Blue / UL 94 V-0)
2	Dielectric Element	Ceramic	SL/Y5P/Y5U/Y5V	SL: SrCO ₃ /TiO ₂ /Bi ₂ O ₃ /CaCO ₃ Y5P: BaTiO ₃ /Bi ₂ O ₃ /SnO ₂ /CeO ₂ Y5U: BaTiO ₃ /ZrO ₂ / CaCO ₃ Y5V: BaTiO ₃ / WO ₃ / CeO ₂
3	Solder	Tin-silver	Sn96.5-Ag3-Cu0.5	Sn96.5-Ag3-Cu0.5
4	Electrodes	Ag	SP-160PL SP-260PL	Silver 、 Glass frit
5	Leads wire	Tinned copper clad steel wire	0.55±0.05 mm	Substrate metal: Fe & Cu Surface plating: Sn 100%(3~7μm)